

SECTION 9

SIGNALS AND LIGHTING (SG)

9-1 GENERAL - Signals, lighting, and electrical system improvements shall be installed in accordance with the approved project improvement plans, these Construction Standards, the latest edition of Caltrans Standard Specifications, as recommended by the manufacturer and as specified by the City Engineer. These Construction Standards and the manufacturer's guidelines shall be present at the construction site at all times.

All components of signals and street lights shall be powder coated black, where feasible, unless minor modifications are made to existing street lights, where any new components shall be made to match the existing signal or street light.

9-2 FOUNDATIONS - Placement of all foundations shall be verified by the Public Works Inspector prior to installation.

There shall be a minimum 6-inch high curb around the signal controller/service pad, excluding the sidewalk/roadway side of the pad. The minimum curb height shall increase as necessary to ensure no steeper than a 2:1 slope of the native material around the pad.

Signal pole anchor bolts shall be aligned to ensure a maximum mast arm offset of two (2) degrees from perpendicular to the roadway.

9-3 STANDARD, STEEL PEDESTAL AND POST - Any 1B standard having a signal head display, four (4) sections or larger, shall be installed under the following criteria:

A. Four Section Displays - 4-section displays will be side (SV-1-T or SV-2-T) mounted and the pole shall be 13 feet in height. A PVC cap shall be provided as a pole cap.

B. Five Section Displays - 5-section displays shall be side (SV-1-T or SV-2-T) mounted and the pole shall be 14 feet in height. A PVC cap shall be provided as a pole cap.

C. Field Welding - Field welding shall not be permitted without the permission of the City Engineer. Only persons certified by the pole manufacturer shall perform any welding on traffic signal or lighting poles in the City's right of way.

D. Future Tenons - All future tenons shall be covered with a plastic cap and a pull wire shall be installed to the tenon.

9-4 CONDUIT MATERIAL - All conduits shall be gray PVC, minimum Schedule 40, two to three inches in diameter.

9-5 CONDUIT INSTALLATION - All trenches in existing streets shall be constructed in accordance with these standards:

A. Depth - All new conduits placed in the roadway, with the exception of the conduit between the detector handhole and the first pull box, shall be buried at a depth of 30-inches below finish grade or 18-inches below finished sub grade.

- B. Signal Interconnect** - Unless otherwise specified, all signal interconnect shall be installed using 2-inch conduit with 2-foot radius, 90 degree sweeps into number 6 pull boxes. The bell end of the sweep shall be in the pull box.
- C. End Sealing** - After conductors have been installed, the ends of the conduit shall be sealed with a duct seal type of sealing compound.
- D. Trench Width** - The trench shall be a maximum of 6-inches wide and 2-inches wider than the outside diameter of the conduit to be installed. There shall be a minimum of 1-inch clearance between the conduit and the trench wall.
- E. Trench Backfill** - The trench shall be backfilled with class 2 aggregate base or slurry cement backfill per the "Streets" section of these Construction Standards.

9-6 PULL BOXES - All pull boxes shall be installed in accordance with these standards

- A. Locations** - Pull boxes shall not be placed in an accessible ramp area. The bottom of pull boxes shall be bedded in 6-inches of clean crushed rock. The pull box rim and lid shall be flush with surrounding surface or 1-inch above finish grade in unpaved areas.
- B. Conduit** - Conduit termination in the pull box shall be a minimum of 2-inches from the sides of the box, 2-inches above the crushed rock, and at least 8-inches below the bottom of the pull box cover. Conduit shall enter and exit the pull box quadrants relative to the direction of the run.
- C. Box Type** - All pull boxes shall be a minimum of number 5 unless otherwise approved. Pull boxes and covers shall be precast reinforced concrete unless otherwise approved. Covers shall read "TRAFFIC SIGNAL" except pull boxes used solely for traffic signal interconnect which shall read "SIGNAL INTERCONNECT".
- D. Abandoned Boxes** - All pull boxes to be abandoned shall have conductors removed from the pull boxes and conduits and the pull box shall be removed. The remaining hole shall be backfilled and compacted with similar material as the surrounding material. If within a sidewalk, the entire square of sidewalk shall be removed and replaced.

9-7 CONDUCTORS - Conductor installation in new conduits shall be limited to 26 percent fill of the conduit maximum. Conductors installed in existing conduits shall be limited to 40 percent fill of the conduit maximum.

- A. Grounding Conductors** - Equipment grounding conductors shall be #8 solid bare copper.
- B. Identification** - Conductors shall be identified and marked at each terminal point or as directed by the City Engineer. Conductor for each vehicle and pedestrian phase shall be bundled together and banded with plastic tie-wrap labels in all pull boxes and controller cabinet.
- C. Signal Interconnect** - Signal interconnect cable shall consist of six pairs, number 20 stranded copper conductors. Each pair shall be wrapped with an aluminum polyester shield. No splicing of signal interconnect cable is allowed. Six feet of slack of signal interconnect cable shall be provided at each pull box. Fifty feet of slack shall be provided in the home run pull box.

D. Wiring Installation - Field conductor wiring shall not be doubled up on any single wire connector. For conductor wire sizes larger than number 10, connections shall be spliced by the use of "C" shaped compression connectors as shown in the Standard Plans.

Ends of spare conductors shall be taped and water sealed with Scotch Kote, or approved equal. Grounding conductor splicing shall be water sealed with two (2) applications of Scotch Kote, or approved equal.

9-8 BONDING AND GROUNDING - All signal equipment and electrical systems shall be effectively grounded in accordance with these standards.

A. Grounding Electrodes - Grounding electrodes shall be of copper clad steel rod, not less than 5/8-inch in diameter by 8-feet in length. A grounding electrode shall be installed in all electrical services and controller foundations. They shall be spaced a minimum of 6-feet apart.

The grounding electrode rod in the Controller Assembly shall be paralleled with the grounding electrode rod in the Service. This connection shall consist of a continuous solid #6 bare conductor.

B. Grounding Connections - The ground connection shall be on the line side of the electrical entrance terminal block. A continuous # 6 bare copper conductor shall connect the ground bus in the electrical service, the grounding electrode in the service, the grounding electrode in the controller, and the ground entrance lug in the controller cabinet.

C. Bonding - The equipment bonding conductor for all standards shall be visible and accessible after completion of work.

9-9 TESTING - The contractor shall notify the City Engineer at least five (5) working days prior to installation of a tested controller assembly and/or electrical service.

A. Ground Testing - Before electrical power can be connected, the grounding electrode shall be tested for earth ground resistance. The Contractor shall perform this ground resistance testing in the presence of the Public Works Inspector. The earth ground resistance shall be a maximum of 5-ohms.

B. Functional Testing - Functional testing shall be performed for five (5) working days prior to signal activation. All systems shall be in place before functional testing can begin.

A shutdown of the electrical system resulting from damage caused by public traffic, or from a power interruption, shall not constitute discontinuity of the functional test.

During interconnect cable installation, the Contractor shall, in the presence of the Public Works Inspector, perform a high resistance to ground test, DC resistance test and a dB attenuation loss test. The Contractor shall supply factory specifications prior to the test. The Contractor shall notify the City Engineer at least 48 hours prior to interconnect cable installation.

9-10 EMERGENCY VEHICLE PREEMPTION EQUIPMENT - The Contractor shall supply emergency vehicle preemption equipment for new signal construction as required on the approved plans. Preemption equipment shall be Opticom Priority Control System 722 detectors, or approved equals.

A. Existing Signals - Where existing signals are being modified, and said signals are already equipped with emergency vehicle preemption equipment, the Contractor shall perform any necessary remodel and reinstallation of said equipment as required by the plans or as directed by the City Engineer.

B. Labels - Labels shall consist of; banded colored tape visible at the preemption detector, signal standard hand hole, adjacent pull box, and the Controller Cabinet. Cables in the Controller Cabinet shall have tie wrap labels with appropriate phasing descriptions. Preemption cables shall be labeled in the following manner:

1. Phase 2 & 5 - single gray band
2. Phase 4 & 7 - double gray band
3. Phase 1 & 6 - triple gray band
4. Phase 3 & 8 - quadruple gray band

9-11 SIGNAL SECTIONS - Signal sections shall be 12-inch mold-cast aluminum. All signal sections, faces, backplates and components shall be painted black. Signal poles shall be black powder coated.

A. Signal Faces - All signal faces shall be aluminum. Signal faces shall have 12-inch LED displays, unless otherwise specified.

B. Backplates - All vehicle signal sections shall include aluminum backplates with perforated louvers.

C. Front Screen - The front screen shall be plastic.

D. Terminal Compartments - Terminal compartments (TV & SV) and mast arm slip fitters (MAS & MAT) shall be bronze. Where no vehicle or pedestrian display is to be installed on the side of a signal pole, a terminal compartment only shall be installed on the signal pole at the vehicle display position. All signal display wiring from the signal mast arm shall terminate at this location.

E. Extra Support - Extra support shall be incorporated with the use of a SV-3-TA or SV-3-TB display, or if any display on a side mount is larger than a 3-section 12" display. The extra support method shall consist of a 1-inch stand off w/ 1/4" X 20 threaded hole. The stand-off shall be banded to the signal standard, 3-inches below the bottom of the top slip fitting of the displays' 1/2-inch riser. A 1/4-inch hole shall be drilled in the center of the 1/2-inch riser to match the position of the thread hole on the stand-off. The riser shall be attached to the standoff with a 1/4" X 20 bolt, which shall include a lock washer and flat washer.

F. Sealing - All signal display mounting assembly top members shall be watertight. The watertight sealing method shall be a 1/2" thick layer of clear silicone around the top jointing member of all displays. Additional sealant shall be installed in the same manner on all plugs installed in the top of any signal display. All MAT and MAS mounts shall be sealed with approved clear silicone around the tenon attachment area, including the through bolt and tenon openings. The sealant shall be 35 year rated. There shall be no substitution for the silicone sealant.

9-12 PEDESTRIAN DISPLAYS -

A. Type - All pedestrian displays shall be 16-inch LED countdown type. Pedestrian signals shall be aluminum Type "A" with international symbols.

B. Mounting - Pedestrian heads shall be mounted on the intersection side of the signal pole unless otherwise directed by the Engineer. Pedestrian head mounts shall be clam shell type with bronze mounting

hardware. Mounting shall include one Allen head screw for opening and all wiring shall be quick connect type (plug in).

9-13 VIDEO DETECTION - All signalized intersections shall be provided with traffic data detection by means of video monitoring. Video detection equipment shall consist of a complete Traficon system, or approved equal.

A. Camera Units - Cameras shall be 1/3-inch Interline Transfer Sony Super HAD CCD type with high sensitivity and 580 TV lines of resolution. The detection needs of the intersection shall determine the total number of cameras required. Cameras shall be pedestal mounted on a manually adjustable swivel head with cable feed through.

B. Detector Boards - Video Image Processor (VIP) detectors shall be provided to monitor all cameras as needed at the intersection. VIP's shall be Type 170 and TS-2 compatible, card rack plug-in modules, capable of monitoring two cameras per unit. The detector shall provide 24 zones per camera and consist of 4-10 detection lines with each zone capable of direction sensitivity. Detector modules shall be PC compatible with graphical software for displaying image requests, freeze frames and for modifying zone layout, and shall be programmable by remote keypad..

C. Video Monitor - Video monitors shall be provided in signal cabinets for displaying camera output and modifying zone layouts and detector settings. The monitor shall be EIA or CCIR Standard (Dual System) with a minimum 9-inch picture display and greater than 1000 TV line horizontal resolution.

9-14 VEHICLE DETECTORS - If vehicle detector loops are permitted they shall be inductive Type "A" loops. The loops nearest the stop bar shall be placed one (1) foot from the stop bar.

A. Loop Wire - Vehicle loop wire shall be Type 1, RHW-USE, neoprene-jacketed, cross-linked polyethylene insulated, #12 stranded copper. Lead-in cable shall be Type B copper. Tinned copper shall not be permitted. Lead-in cables shall not be spliced between the termination point (the pull box adjacent to loop detectors) and the controller cabinet terminals. All wires for each detector loop shall terminate in the nearest pull box, not the hand hole.

B. Hand Holes - Detector hand holes shall be Type "B". Hand holes shall be placed so they line up with roadway stripes to minimize the frequency of vehicle tires driving over the handhole covers. A sufficient number of handholes shall be placed so that detector loop saw cuts shall not cross adjacent lanes of travel.

C. Verification - The contractor shall give notice to the City Engineer 48 hours prior to saw cutting for loop installation. The Public Works Inspector shall verify all loop locations.

D. New Pavement Installation - Signal loops installed in new pavement shall be placed in the lift of asphalt concrete immediately below the final lift. The bottom lift shall be a minimum of 2-inches thick where the traffic signal loops will be installed. New loops shall be installed in 1¾" slots cut in the bottom lift.

E. Labels - Labels shall consist of banded colored tape visible in the pull boxes, where the loop wire is spliced to the detector lead-in cable.

1. Loop wires shall be labeled in the following manner:

- a. Lane 1-black
- b. Lane 2-red

- c. Lane 3-blue
 - d. Lane 4-white
 - e. Lane 5 -yellow
 - f. Right turn lane - orange
2. Loop detectors shall be clearly marked to reference their location in relation to the limit line and lane. The loop closest to the crosswalk in the left most lane, shall be labeled as loop number 1-1. The second loop in the same lane shall be labeled 1-2, and so on.
3. The start and end leads of a loop detector shall be clearly marked by a means of plastic tie wrap labels.

F. Testing - During loop installation, the Contractor shall, in the presence of the Public Work Inspector, perform a high resistance test and an inductive reactance test.

G. Circuitry - Adjacent loops on the same sensor unit channel shall be wound in opposite directions. All loops shall be wound in a manner such that any adjacent loop will be wound in the opposite direction. The loop at the limit line, closest to the center median (lane 1), shall be wound in a clockwise direction. The next loop back in the same lane shall be wound in a counter-clockwise direction and so on. The loop detector in lane 2 closest to the limit line, shall be wound in a counterclockwise direction.

9-15 PEDESTRIAN PUSH BUTTON ASSEMBLIES - Pedestrian push buttons shall be aluminum Type “B” per the Caltrans Standard Plans, with metal international symbol signs. Buttons shall be solid state, two tone audible, momentary LED type and shall meet all Americans with Disabilities Act guidelines.

Pedestrian push buttons shall be within five (5) feet from the edge of the access ramp. They shall be placed 36-inches above the grade of the closest edge of sidewalk and require a horizontal reach of no more than 18-inches outside the closest edge of sidewalk.

9-16 EXISTING ELECTRICAL EQUIPMENT - All existing traffic control devices, lighting devices, signs, and equipment to be removed and not reused in the work shall be salvaged, unless otherwise specified or directed by the City Engineer. Salvageable equipment shall remain the property of the City. Equipment determined to be unsalvageable by the City Engineer shall become the property of the Contractor. The Contractor shall deliver salvaged equipment to the City’s Corporation Yard or other location as directed by the City Engineer.

Damaged conduits deemed unusable shall be removed from existing pull boxes and the ends plugged solid with grout. Existing conductors shall be removed from said conduits prior to plugging. Contractor shall dispose of said conductors.

Abandoned conduits deemed reusable shall have the line blown out, existing conductors shall be removed, a number 10 green locate wire shall be installed, and the ends of the conduits shall be sealed.

9-17 STREET LIGHT POLES - All street light poles shall be galvanized steel or aluminum, painted black or as shown on the plans. Antique style aluminum poles shall be used in the downtown area or where required by the City Engineer.

A. Galvanized Steel Poles - Type “A” street lights shall use the “A” series poles as shown in the Street Light Pole Details. Galvanizing shall be as provided in the Standard Specifications.

B. Aluminum Poles - Antique style aluminum poles shall be Antique Street Lamps number PX/CH16/16/S4/ANBK, with aluminum roadway arm BHC45/1/ANBK, or approved equal.

9-18 STREET LIGHT SERVICE - All street light systems shall have underground service provided. Service points shall be provided within a utility easement immediately adjacent to, or within, the right-of-way, and shall be open and easily accessible to the street frontage.

A. Direct Service - A direct underground service consists of one (1) or two (2) lights being served from a single service point. The service point may be in the form of a pull box installed by the developer or a service pedestal provided by the utility district.

B. Multiple Service - Multiple service is three (3) or more lights being served from a single service point. The service point shall be a pull box. Multiple systems shall have a service cabinet normally located adjacent to the service point between the service point and the light system.

9-19 LUMINAIRES - Luminaires shall be either 250-watt high pressure sodium (HPS) or antique style luminaires as shown on the plans. Antique, octagonal shaped lamps shall be used in the downtown area or where required by the City Engineer.

A. HPS Specifications - High pressure sodium luminaires shall conform to the following specifications:

1. Medium, cutoff, Type II or III lighting distribution (MSII or MSIII).
2. 120 volt ballast with lag-type magnetic regulator.
3. Power door ballast assembly & plug in starter.
4. Photo eye receptacle with shorting cap.
5. Flat glass lens.
6. Polyester fiber gasket breathing seal.
7. Voltage tap connection.

B. Antique Luminaires - Antique style luminaires shall be Antique Street Lamps Number HLT30/150S/ACS/GR3/TB3/ANBK/PEB1 or TR30/150S/MOG/ACS/GR3/120/ANBK/PEB1 or approved equal.

C. Photoelectric Controls - Photoelectric controls shall be Type II and shall be pole top mounted.

D. Shielding - Shielding shall be required on the mast arm side of all luminaires installed on same side of the street as residential properties.

9-20 PAINTING - Painting of electrical equipment and materials shall conform to the provisions of the Standard Specifications and these standards.

A. Cleaning - All ferrous surfaces to be painted shall be cleaned as provided in the State Standard Specifications prior to applying the vinyl wash primer or prime coat. Blast cleaning of galvanized metal surfaces in good condition, as determined by the City Engineer, will not be permitted.

Existing equipment to be painted in the field shall be washed with a stiff bristle brush using a solution of water containing 2-tablespoonfuls of heavy-duty detergent powder per gallon. After rinsing, all surfaces higher than 8-feet above ground level shall be wire brushed with a coarse, cup shaped, power driven brush to remove all poorly bonded paint, rust scale, corrosion, grease, or dirt. Any dust or residue remaining after wire brushing shall also be removed prior to priming. All surfaces between the ground level and 8-feet in height shall have all paint, rust, scale, corrosion, grease, and dirt removed to bare metal.

- B. Coating** - Immediately after cleaning, all bare metal in corrosive atmospheres, all galvanized surfaces, and all nonferrous metal surfaces, shall be coated with Pre-Treatment, Vinyl Wash Primer, followed by two prime coats of Zinc Chromate Primer for metal. Pre-Treatment, Vinyl Wash Primer may be omitted on bare metal surfaces and the prime coats shall be applied immediately after cleaning.
- C. Spot Finishing** - Equipment previously finished as specified shall be given a spot-finishing coat on newly primed areas, followed by a finishing coat over the entire surface.
- D. Painting** - All paint coats may be applied either by hand brushing or by approved spraying machine in the hands of skilled operators. The work shall be done in a neat and workmanlike manner. The City Engineer reserves the right to require the use of brushes for the application of paint should the work done by the paint spraying machine prove unsatisfactory.

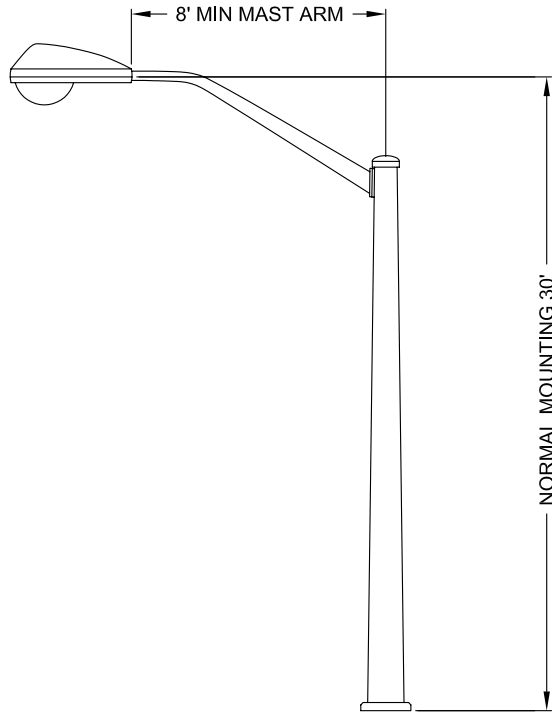

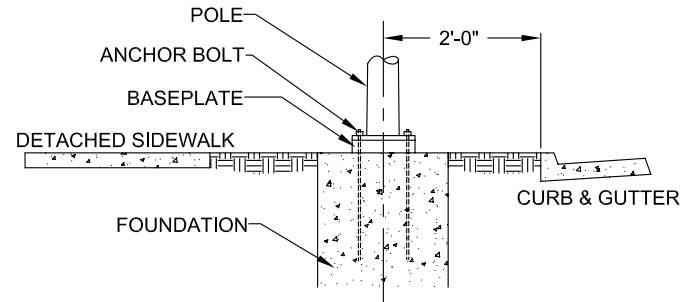
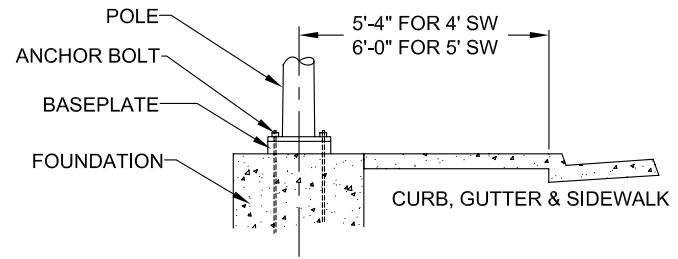

TYPE "A" STREET LIGHT



NOTES:

1. FOUNDATION AND ACHOR BOLTS TO BE PER APPROVED IMPROVEMENT PLANS

	PUBLIC WORKS DEPARTMENT ENGINEERING DIVISION	
	STREET LIGHT POLE	
APPROVED BY: 		
PUBLIC WORKS DIRECTOR / CITY ENGINEER		
SCALE: NONE	DRAWN BY: BPJ	DATE: MAR 3, 2009
		SG - 1