

CITY OF GRASS VALLEY  
ENGINEERING DIVISION  
IMPROVEMENT PLANS FOR

# 2024 ANNUAL MEASURE E STREET REHABILITATION PROJECT

PROJECT NO. 23-09

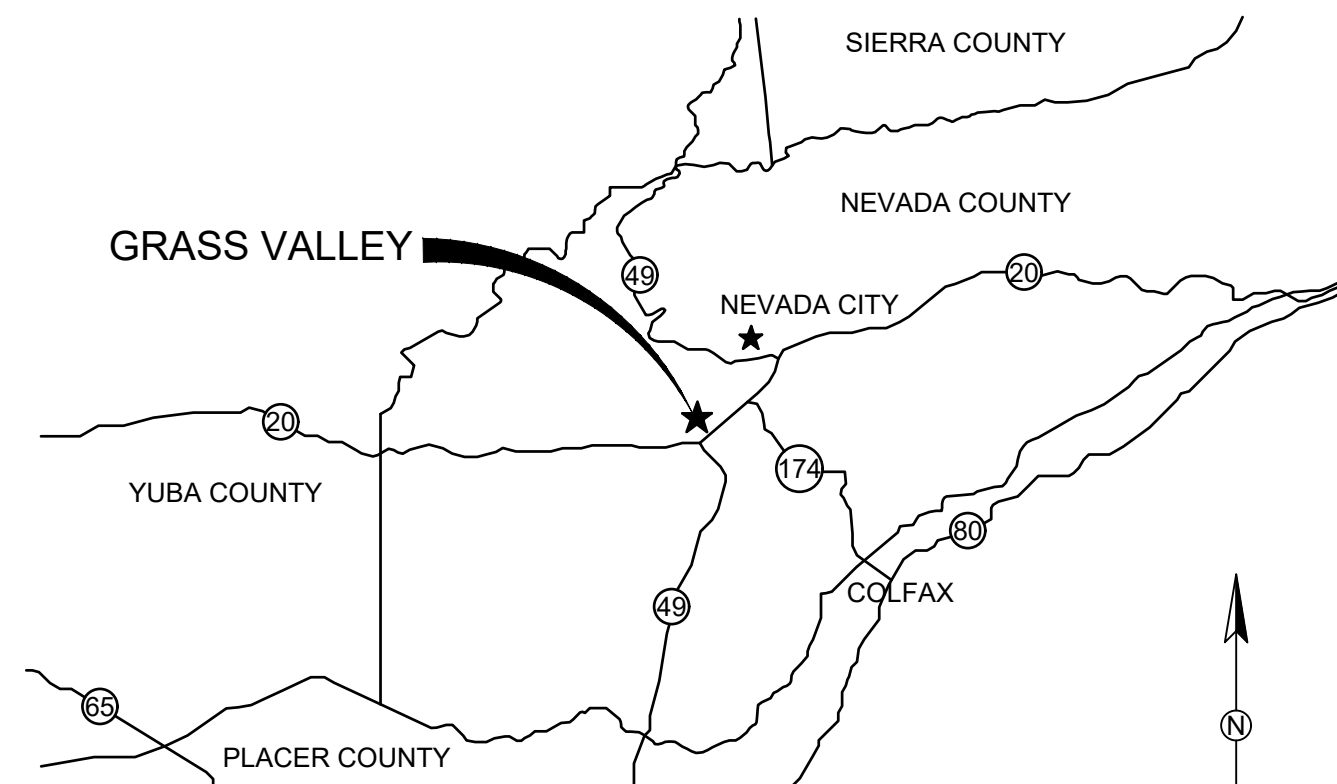
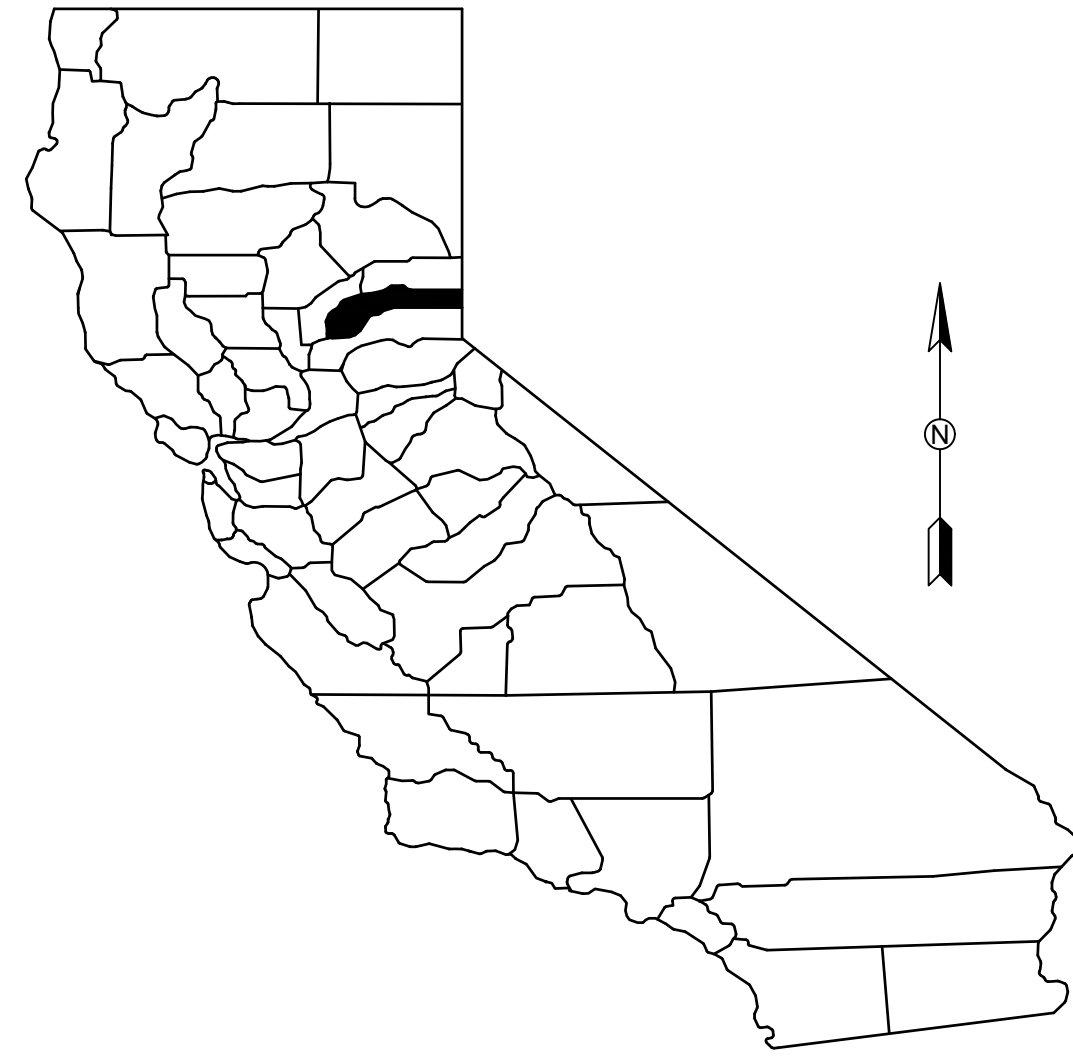

VICINITY MAP  
NO SCALE



LOCATION MAP  
NO SCALE

**CONSTRUCTION LEGEND:**

	STATION LINE
	(E) CURB; DIKE; DRIVEWAY
	(E) WALL
	(E) FENCE
	LOT/ROW LINE
	EASEMENT LINE
	(E) GAS
	(E) SEWER AND SIZE
	(E) STORM DRAIN AND SIZE
	(E) TELEPHONE
	(E) WATER
	(P) WATER
	(E) CONTOUR LINES
	DRAINAGE INLET
	FIRE HYDRANT
	WATER METER BOX
	MANHOLE (SS, SD, TEL, ELEC)
	VALVE (GAS, TEL, ARV, WTR)
	GUY POLE
	GUY WIRE
	LIGHT POST
	POLE
	SINGLE POLE SIGN
	MAILBOX
	TREE
	BENCHMARK
	(P) SPOT ELEVATION
	DENOTES STD PLAN NO/DETAIL NO
	CONSTRUCTION KEYNOTE

**SHEET INDEX:**

1. TITLE SHEET
2. CONSTRUCTION PLAN ( FINNIE, NORTH SCHOOL, NORTH CHURCH)
3. CONSTRUCTION PLAN (NORTH AUBURN, CHESTER)
4. CONSTRUCTION PLAN (LINDEN, ALTA VISTA)
5. CONSTRUCTION PLAN (IVY)
6. DETAILS

**ABBREVIATIONS:**

AB	AGGREGATE BASE	PCC	PORTLAND CEMENT CONCRETE
AC	ASPHALT CONCRETE	ℙ	PROPERTY LINE
C&G	CURB AND GUTTER	(P)	PROPOSED
CF	CUBIC FOOT	PSI	POUNDS PER SQUARE INCH
℄	CENTERLINE	PUE	PUBLIC UTILITY EASEMENT
CY	CUBIC YARD	PVC	POLYVINYL CHLORIDE
E	ELECTRIC	PVMT	PAVEMENT
(E)	EXISTING	R	RADIUS
ELEV	ELEVATION	RCP	REINFORCED CONCRETE PIPE
EP	EDGE OF PAVEMENT	RW	RETAINING WALL
FL	FLOW LINE	ROW	RIGHT OF WAY
FT	FEET	SD	STORM DRAIN
FTG	FOOTING	SF	SQUARE FOOT
G	GAS	SY	SQUARE YARD
ID	INSIDE DIAMETER	ST	STREET
IE	INVERT ELEVATION	STA	STATION
L	LEFT	STD	STANDARD
LF	LINEAR FOOT	SW	SIDEWALK
MAX	MAXIMUM	SS	SANITARY SEWER
MH	MANHOLE	TBC	TOP BACK OF CURB
MIN	MINIMUM	TBW	TOP BACK OF WALK
MISC	MISCELLANEOUS	TFC	TOP FACE OF CURB
NO	NUMBER	TC	TOP OF CURB
NTS	NOT TO SCALE	TP	TELEPHONE POLE
OD	OUTSIDE DIAMETER	TS	TRAFFIC SIGNAL
		TYP	TYPICAL

**NOTES:**

1. THE CONTRACTOR SHALL POSSESS A VALID CALIFORNIA CLASS A CONTRACTORS LICENSE, OR A COMBINATION OF THE FOLLOWING CLASSES, (C-8 - CONCRETE CONTRACTOR, C12 - EARTHWORK AND PAVING CONTRACTOR, C36 - PLUMBING CONTRACTOR AND D63 - CONSTRUCTION CLEANUP) AT THE TIME OF THE BID AWARD, AND THE LICENSE SHALL REMAIN IN EFFECT THROUGHOUT THE TERM OF THIS CONTRACT.
2. THE CONSTRUCTION METHODS AND MATERIALS SHALL CONFORM TO LATEST EDITIONS OF THE STATE OF CALIFORNIA DEPARTMENT OF TRANSPORTATION STANDARD SPECIFICATIONS AND STANDARD PLANS, THE IMPROVEMENT STANDARDS AND STANDARD DRAWINGS OF THE CITY OF GRASS VALLEY AND THE CALIFORNIA MUTCD. IN CASE OF CONFLICT, REFER TO THE PROJECT SPECIAL PROVISIONS FOR ORDER OF PRECEDENCE.
3. THE CITY OF GRASS VALLEY HAS MADE EVERY EFFORT TO SHOW LOCATIONS OF ANY AND ALL EXISTING SURFACE AND SUBSURFACE STRUCTURES. HOWEVER, ACTUAL FIELD CONDITIONS AND LOCATIONS CAN VARY CONSIDERABLY FROM PLAN LOCATIONS. THEREFORE, THE CITY OF GRASS VALLEY CANNOT, AND DOES NOT, ASSUME RESPONSIBILITY OF THE EXISTENCE OR LOCATION OF ANY STRUCTURE SUCH AS, BUT NOT LIMITED TO, UTILITIES, PIPELINES AND SEWERS. THE CONTRACTOR IS RESPONSIBLE FOR CONTACTING ALL AGENCIES AND/OR OWNERS TO VERIFY THIS INFORMATION PRIOR TO AND DURING CONSTRUCTION OF IMPROVEMENTS SHOWN HEREON, AND TO CONTACT THE ENGINEER IN THE EVENT OF ANY SIGNIFICANT DISCREPANCY.
4. THE CONTRACTOR IS RESPONSIBLE FOR DETERMINING THE LOCATION OF, AND PROTECTING ALL EXISTING UTILITIES AND REPAIRING DAMAGE TO EXISTING UTILITIES. THE CONTRACTOR SHALL CONTACT UNDERGROUND SERVICE ALERT (1-800-227-2600) TWO WORKING DAYS PRIOR TO COMMENCEMENT OF EXCAVATION.

**RECORD DRAWINGS NOTE:**

ALL INFORMATION SHOWN ON THESE PLANS HAS BEEN PREPARED BY, OR UNDER THE DIRECTION OF, THE UNDERSIGNED ENGINEER. ADJUSTMENTS MADE IN THE FIELD DURING CONSTRUCTION ARE INCLUDED HEREIN AND ARE BASED UPON FIELD OBSERVATIONS MADE UNDER THE DIRECTION OF OR BY THE UNDERSIGNED AND/OR INFORMATION RECEIVED FROM THE CITY CONSTRUCTION INSPECTOR, PROJECT CONTRACTORS AND OTHER SOURCES WHEN THE ENGINEER IS ADVISED IN WRITING OF SUCH ADJUSTMENTS. THE ENGINEER PREPARING THESE PLANS WILL NOT BE RESPONSIBLE FOR, OR LIABLE FOR, CHANGES TO THESE PLANS NOT AUTHORIZED BY THE ENGINEER. ADJUSTMENTS MADE IN THE FIELD WERE NOT SURVEYED AND THE ACCURACY OF THESE DRAWINGS WITH RESPECT TO THOSE ADJUSTMENTS IS NOT GUARANTEED BY THE ENGINEER OR THE CITY OF GRASS VALLEY; FIELD VERIFICATION OF ALL IMPROVEMENTS IS RECOMMENDED.

**UTILITY/EMERGENCY CONTACTS:**

WATER/SEWER/ STORM DRAIN:	CITY OF GRASS VALLEY 125 E MAIN ST GRASS VALLEY, CA 95945	530-274-4350
FIRE PROTECTION:	CITY OF GRASS VALLEY 125 E MAIN ST GRASS VALLEY, CA 95945	530-274-4370
ELECTRICITY/GAS:	PG&E 788 TAYLORVILLE RD GRASS VALLEY, CA 95945	530-477-3260
TELEVISION:	COMCAST 427 EATON RD CHICO, CA 95973	530-206-6172
PHONE:	AT&T 12824 EARHART DRIVE AUBURN, CA 95602	530-888-2031

DATE	ENGINEER SIGNATURE (STAMP OR SEAL)
CITY CLERK	"APPROVED BY THE CITY COUNCIL OF THE CITY OF GRASS VALLEY THE 23 DAY OF FEBRUARY 2024."
CITY ENGINEER	75378 R.C.E. 2/29/24 DATE
PROJECT ENGINEER	2/29/24 DATE

NOTE:  
THE CITY OF GRASS VALLEY OR ITS OFFICERS OR AGENTS SHALL NOT BE RESPONSIBLE FOR THE ACCURACY OR COMPLETENESS OF ELECTRONIC COPIES OF THIS PLAN SHEET.

CITY OF GRASS VALLEY ENGINEERING DIVISION  
**2024 ANNUAL MEASURE E  
STREET REHAB PROJECT**  
TITLE SHEET

No.	Description	REVISIONS	
		Engr Init	Date



PROJECT NUMBER:  
**23-09**



DRAWN BY:	DATE:
EMA	FEB 2024
CHECKED BY:	DATE:
BPJ	FEB 2024
DRAWING NUMBER:	
<b>2201</b>	
SHEET NUMBER:	
<b>1 OF 6</b>	

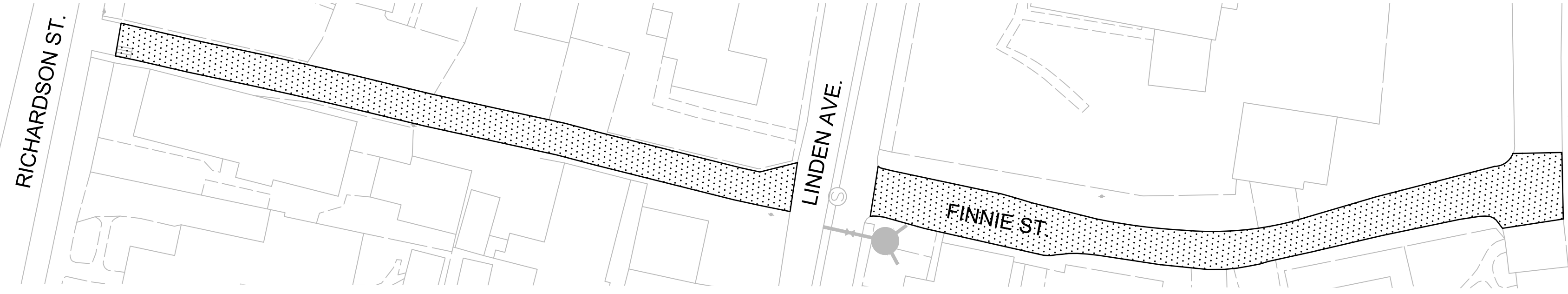

**FINNIE ST**

SCALE: 1"=30'

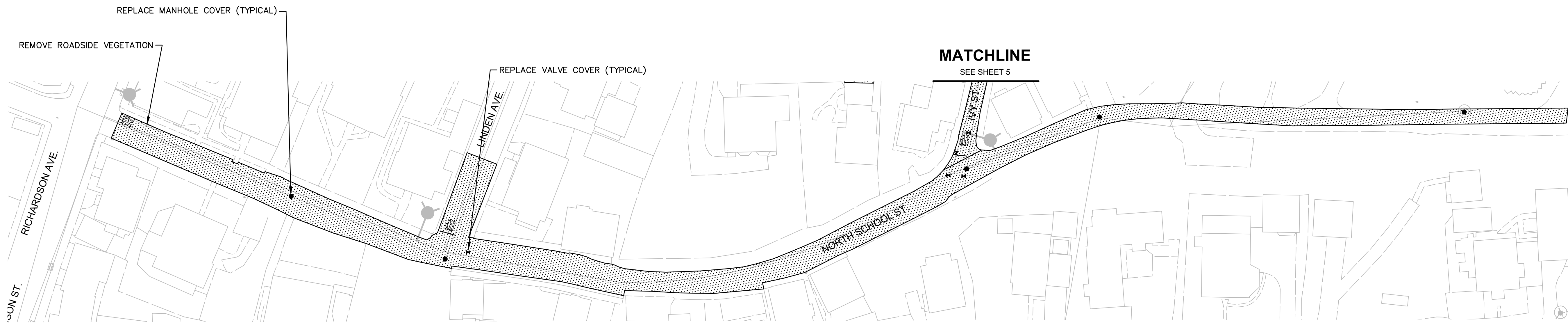

**NORTH SCHOOL ST, LINDEN AVE & IVY ST**

SCALE: 1"=40'

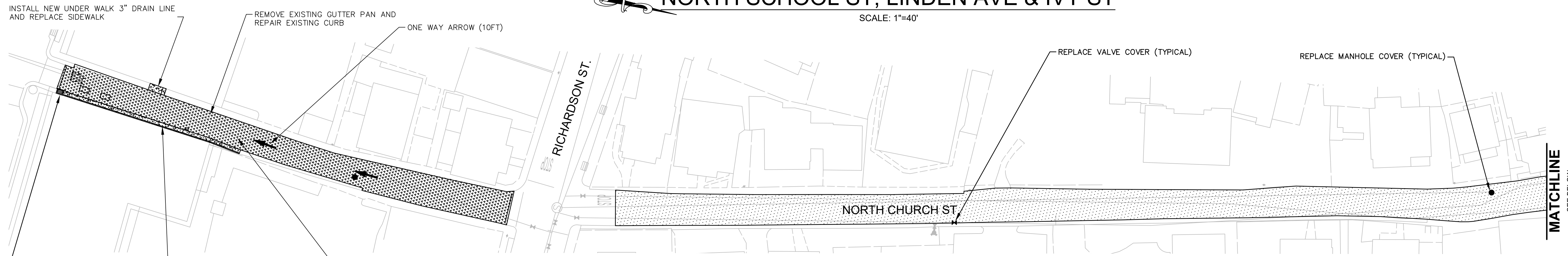

**NORTH CHURCH ST.**

SCALE: 1"=30'

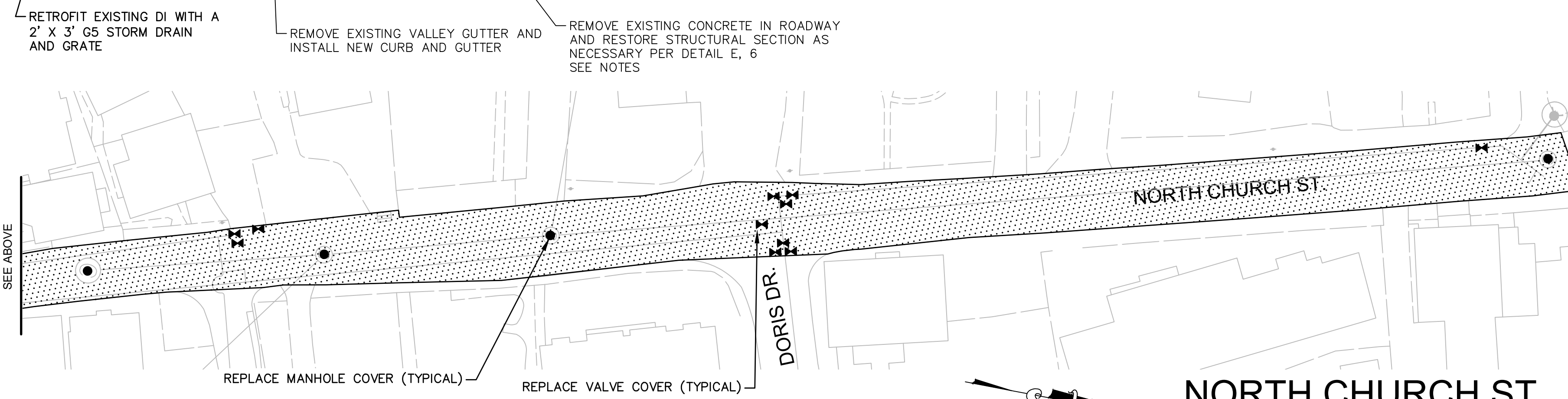

- ◄ REPLACE VALVE COVER AND ADJUST TO GRADE PER DETAIL A, 6
- REPLACE MANHOLE COVER AND ADJUST TO GRADE PER DETAIL A, 6
- ▨ 3" REMOVE AND REPLACE HMA PER DETAIL D, 6
- ▩ 5" REMOVE AND REPLACE HMA PER DETAIL E, 6

**GENERAL NOTES**

1. REMOVE EXISTING CONCRETE SURFACING ON NORTH CHURCH ST BETWEEN WEST MAIN ST AND RICHARDSON ST.
2. ASPHALT CONCRETE IS TO BE CONFORMED TO ALL EXISTING PAVED/CONCRETE DRIVEWAYS WHERE CURB AND GUTTER DO NOT EXIST.
3. ASPHALT CONCRETE IS TO BE CONFORMED TO ALL EXISTING DRAINAGE INLETS AND WATER METER BOXES.
4. ALL VEGETATION SHALL BE REMOVED INSIDE OF PROPOSED PAVEMENT LIMITS.
5. CONTRACTOR IS RESPONSIBLE FOR VERIFYING LOCATION AND DEPTH OF ALL UTILITIES PRIOR TO START OF CONSTRUCTION.
6. DIGOUT LIMITS TO BE MARKED IN THE FIELD BY THE CONTRACTOR AND APPROVED BY THE ENGINEER.
7. ALL UTILITY COVERS AND MANHOLES WITHIN THE HMA PAVING AREA SHALL BE ADJUSTED TO GRADE AS SHOWN OR OTHERWISE SHALL BE CONFORMED TO AS APPROVED BY THE ENGINEER AND THE OWNER.

**STRIPING/MARKING NOTES**

1. ALL PAVEMENT MARKINGS AND STRIPES SHALL BE THERMOPLASTIC, CONFORMING TO THE REQUIREMENTS OF THE CURRENT CALTRANS SPECIFICATIONS AND STANDARD PLANS AND THE PROJECT SPECIAL PROVISIONS, UNLESS OTHERWISE SPECIFIED. ALL CENTER LINE STRIPES SHALL BE 4" IN WIDTH.
2. TEMPORARY PAVEMENT MARKINGS SHALL BE PROVIDED IN ACCORDANCE WITH THE SPECIAL PROVISIONS.
3. THE CONTRACTOR SHALL MARK OUT THE STRIPING LAYOUT AND OBTAIN THE ENGINEER'S ACCEPTANCE PRIOR TO STRIPING. CHANGES MAY OCCUR IN THE FIELD.

NOTE:  
THE CITY OF GRASS VALLEY OR ITS OFFICERS OR AGENTS SHALL NOT BE RESPONSIBLE FOR THE ACCURACY OR COMPLETENESS OF ELECTRONIC COPIES OF THIS PLAN SHEET.

REVISIONS		APPROVAL
No.	Description	Engr Init By Date

PROJECT NUMBER:  
**23-09**

**2024 ANNUAL MEASURE E**  
**STREET REHAB PROJECT**  
 FINNIE ST, NORTH SCHOOL ST, NORTH CHURCH ST



CITY OF GRASS VALLEY ENGINEERING DIVISION

DRAWN BY: **EMA** DATE: **FEB 2024**

CHECKED BY: **BPJ** DATE: **FEB 2024**

DRAWING NUMBER:  
**2201**

SHEET NUMBER:  
**2 OF 6**

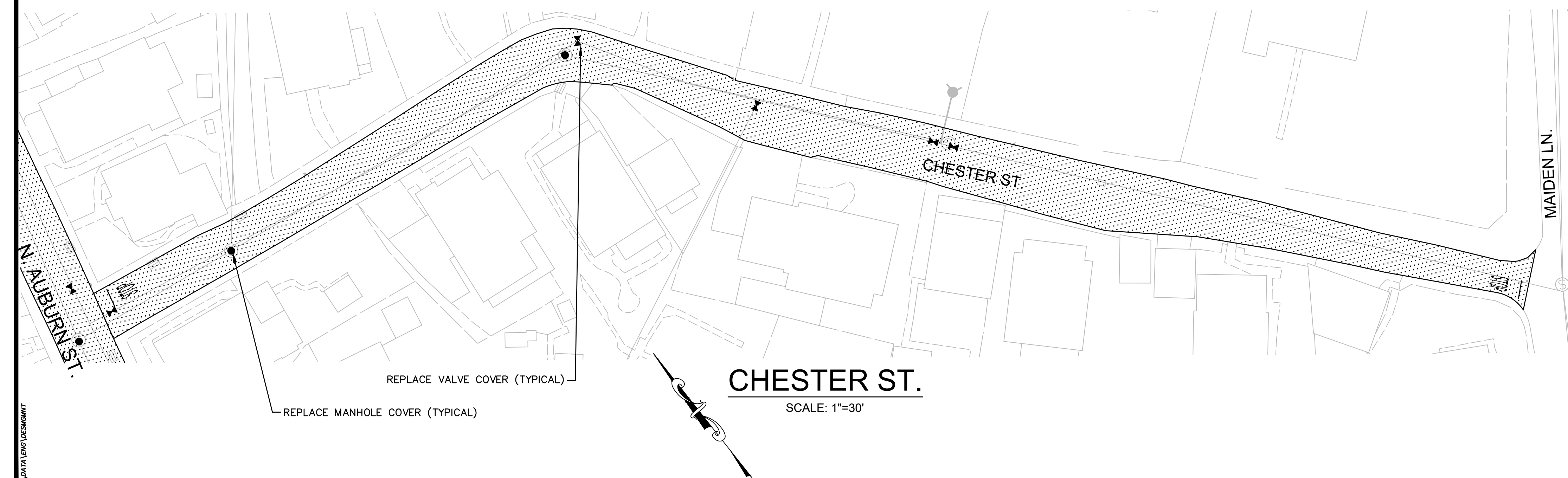
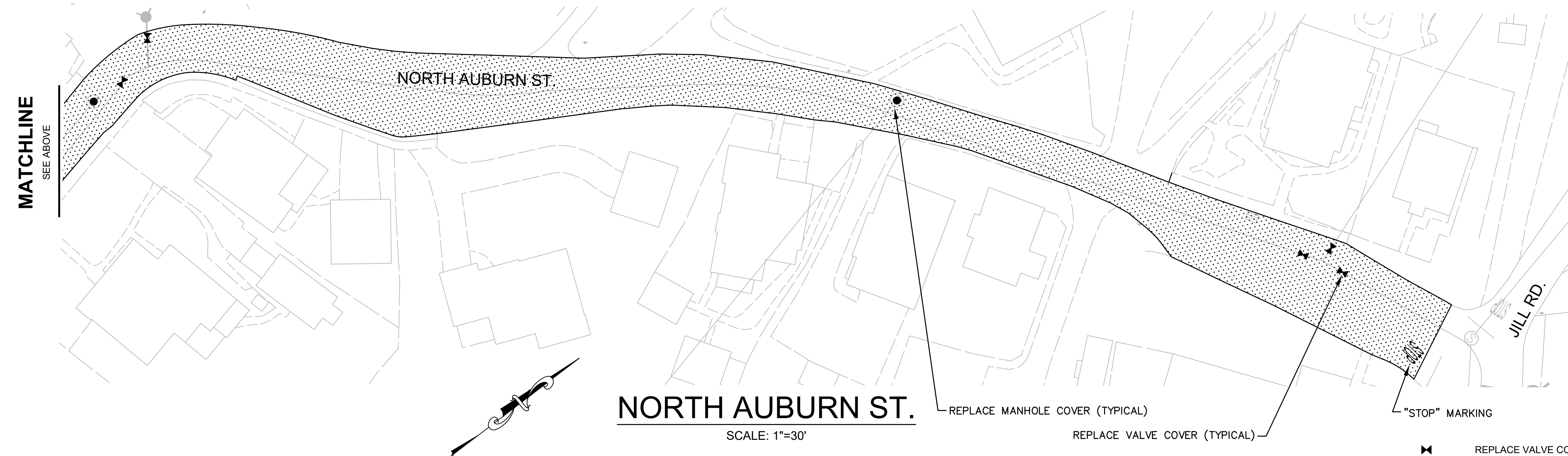
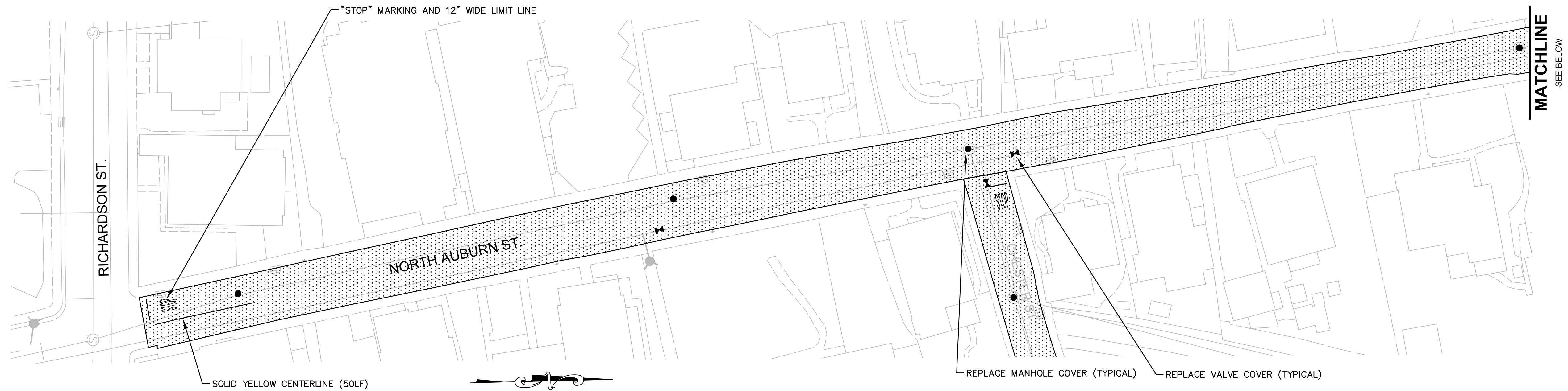

- ✕ REPLACE VALVE COVER AND ADJUST TO GRADE PER DETAIL A, 6
- REPLACE MANHOLE COVER AND ADJUST TO GRADE PER DETAIL A, 6
- ▨ 3" REMOVE AND REPLACE HMA PER DETAIL D, 6
- ▩ 5" REMOVE AND REPLACE HMA PER DETAIL E, 6

**GENERAL NOTES**

1. REMOVE EXISTING CONCRETE SURFACING ON NORTH CHURCH ST BETWEEN WEST MAIN ST AND RICHARDSON ST.
2. ASPHALT CONCRETE IS TO BE CONFORMED TO ALL EXISTING PAVED/CONCRETE DRIVEWAYS WHERE CURB AND GUTTER DO NOT EXIST.
3. ASPHALT CONCRETE IS TO BE CONFORMED TO ALL EXISTING DRAINAGE INLETS AND WATER METER BOXES
4. ALL VEGETATION SHALL BE REMOVED INSIDE OF PROPOSED PAVEMENT LIMITS
5. CONTRACTOR IS RESPONSIBLE FOR VERIFYING LOCATION AND DEPTH OF ALL UTILITIES PRIOR TO START OF CONSTRUCTION.
6. DIGOUT LIMITS TO BE MARKED IN THE FIELD BY THE CONTRACTOR AND APPROVED BY THE ENGINEER
7. ALL UTILITY COVERS AND MANHOLES WITHIN THE HMA PAVING AREA SHALL BE ADJUSTED TO GRADE AS SHOWN OR OTHERWISE SHALL BE CONFORMED TO AS APPROVED BY THE ENGINEER AND THE OWNER.

**STRIPING/MARKING NOTES**

1. ALL PAVEMENT MARKINGS AND STRIPES SHALL BE THERMOPLASTIC, CONFORMING TO THE REQUIREMENTS OF THE CURRENT CALTRANS SPECIFICATIONS AND STANDARD PLANS AND THE PROJECT SPECIAL PROVISIONS, UNLESS OTHERWISE SPECIFIED. ALL CENTER LINE STRIPES SHALL BE 4" IN WIDTH.
2. TEMPORARY PAVEMENT MARKINGS SHALL BE PROVIDED IN ACCORDANCE WITH THE SPECIAL PROVISIONS.
3. THE CONTRACTOR SHALL MARK OUT THE STRIPING LAYOUT AND OBTAIN THE ENGINEER'S ACCEPTANCE PRIOR TO STRIPING. CHANGES MAY OCCUR IN THE FIELD.

**NOTE:**  
THE CITY OF GRASS VALLEY OR ITS OFFICERS OR AGENTS SHALL NOT BE RESPONSIBLE FOR THE ACCURACY OR COMPLETENESS OF ELECTRONIC COPIES OF THIS PLAN SHEET.

REVISIONS		APPROVAL
No.	Description	By Date



PROJECT NUMBER:  
**23-09**

CITY OF GRASS VALLEY ENGINEERING DIVISION

**2024 ANNUAL MEASURE E**

**STREET REHAB PROJECT**

NORTH AUBURN ST, CHESTER ST



DRAWN BY: **EMA** DATE: **JAN 2024**

CHECKED BY: **BPJ** DATE: **JAN 2024**

DRAWING NUMBER:  
**2201**

SHEET NUMBER:  
**3 OF 6**

© DATA FROM GIS/ISSUANCE

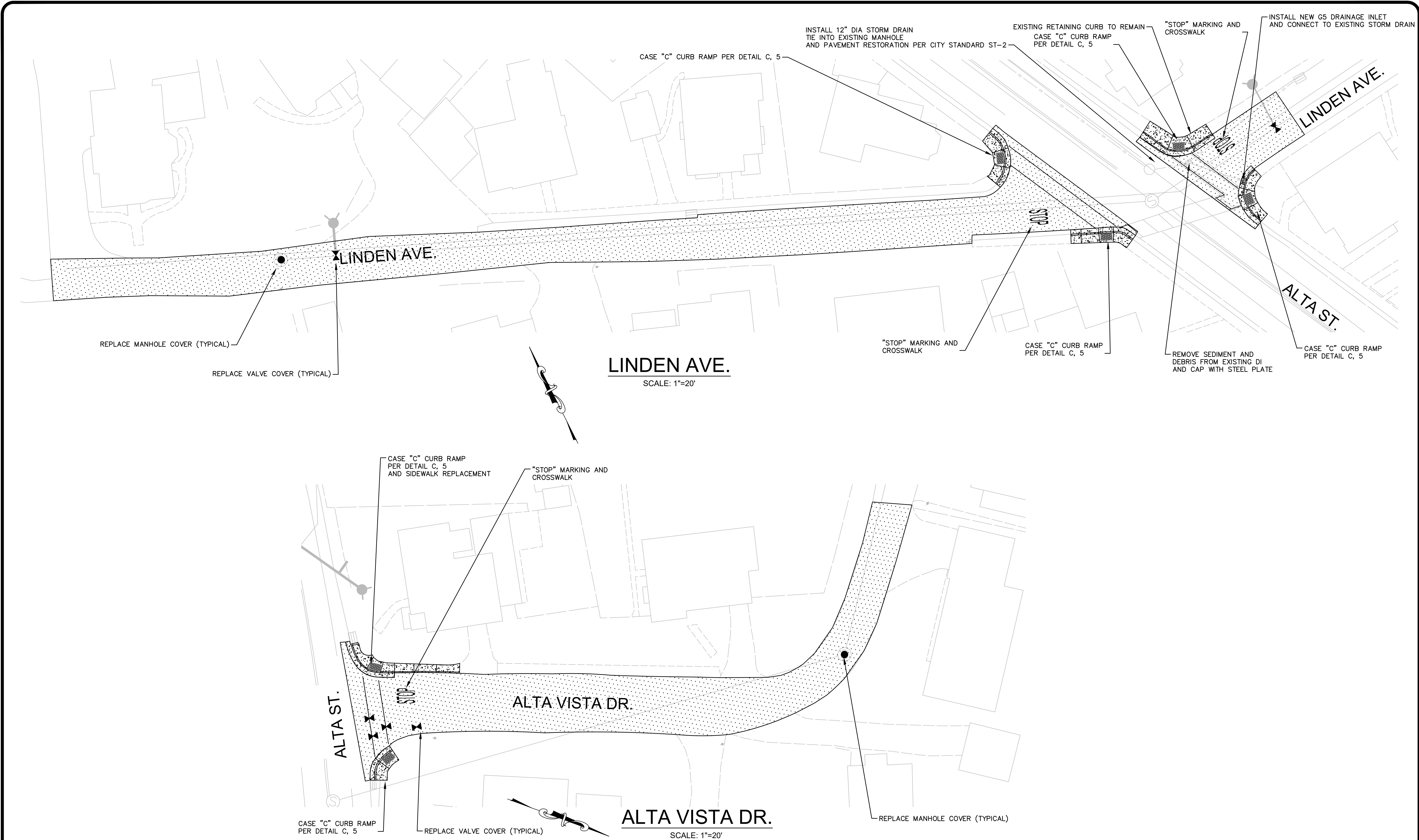

**GENERAL NOTES**

1. REMOVE EXISTING CONCRETE SURFACING ON NORTH CHURCH ST BETWEEN WEST MAIN ST AND RICHARDSON ST.
2. ASPHALT CONCRETE IS TO BE CONFORMED TO ALL EXISTING PAVED/CONCRETE DRIVEWAYS WHERE CURB AND GUTTER DO NOT EXIST.
3. ASPHALT CONCRETE IS TO BE CONFORMED TO ALL EXISTING DRAINAGE INLETS AND WATER METER BOXES
4. ALL VEGETATION SHALL BE REMOVED INSIDE OF PROPOSED PAVEMENT LIMITS
5. CONTRACTOR IS RESPONSIBLE FOR VERIFYING LOCATION AND DEPTH OF ALL UTILITIES PRIOR TO START OF CONSTRUCTION.
6. DIGOUT LIMITS TO BE MARKED IN THE FIELD BY THE CONTRACTOR AND APPROVED BY THE ENGINEER
7. ALL UTILITY COVERS AND MANHOLES WITHIN THE HMA PAVING AREA SHALL BE ADJUSTED TO GRADE AS SHOWN OR OTHERWISE SHALL BE CONFORMED TO AS APPROVED BY THE ENGINEER AND THE OWNER.

**STRIPING/MARKING NOTES**

1. ALL PAVEMENT MARKINGS AND STRIPES SHALL BE THERMOPLASTIC, CONFORMING TO THE REQUIREMENTS OF THE CURRENT CALTRANS SPECIFICATIONS AND STANDARD PLANS AND THE PROJECT SPECIAL PROVISIONS, UNLESS OTHERWISE SPECIFIED. ALL CENTER LINE STRIPES SHALL BE 4" IN WIDTH.
2. TEMPORARY PAVEMENT MARKINGS SHALL BE PROVIDED IN ACCORDANCE WITH THE SPECIAL PROVISIONS.
3. THE CONTRACTOR SHALL MARK OUT THE STRIPING LAYOUT AND OBTAIN THE ENGINEER'S ACCEPTANCE PRIOR TO STRIPING. CHANGES MAY OCCUR IN THE FIELD.

- ✕ REPLACE VALVE COVER AND ADJUST TO GRADE PER DETAIL A, 6
- REPLACE MANHOLE COVER AND ADJUST TO GRADE PER DETAIL A, 6
- ▨ 3" REMOVE AND REPLACE HMA PER DETAIL D, 6
- ▩ 5" REMOVE AND REPLACE HMA PER DETAIL E, 6

NOTE:  
THE CITY OF GRASS VALLEY OR ITS OFFICERS OR AGENTS SHALL NOT BE RESPONSIBLE FOR THE ACCURACY OR COMPLETENESS OF ELECTRONIC COPIES OF THIS PLAN SHEET.

REVISIONS	
No.	Description



PROJECT NUMBER:  
**23-09**

CITY OF GRASS VALLEY ENGINEERING DIVISION  
**2024 ANNUAL MEASURE E**  
**STREET REHAB PROJECT**  
 LINDEN AVE, ALTA VISTA DR



DRAWN BY: **EMA** DATE: **JAN 2024**  
 CHECKED BY: **BPJ** DATE: **JAN 2024**

DRAWING NUMBER:  
**2201**

SHEET NUMBER:  
**4 OF 6**

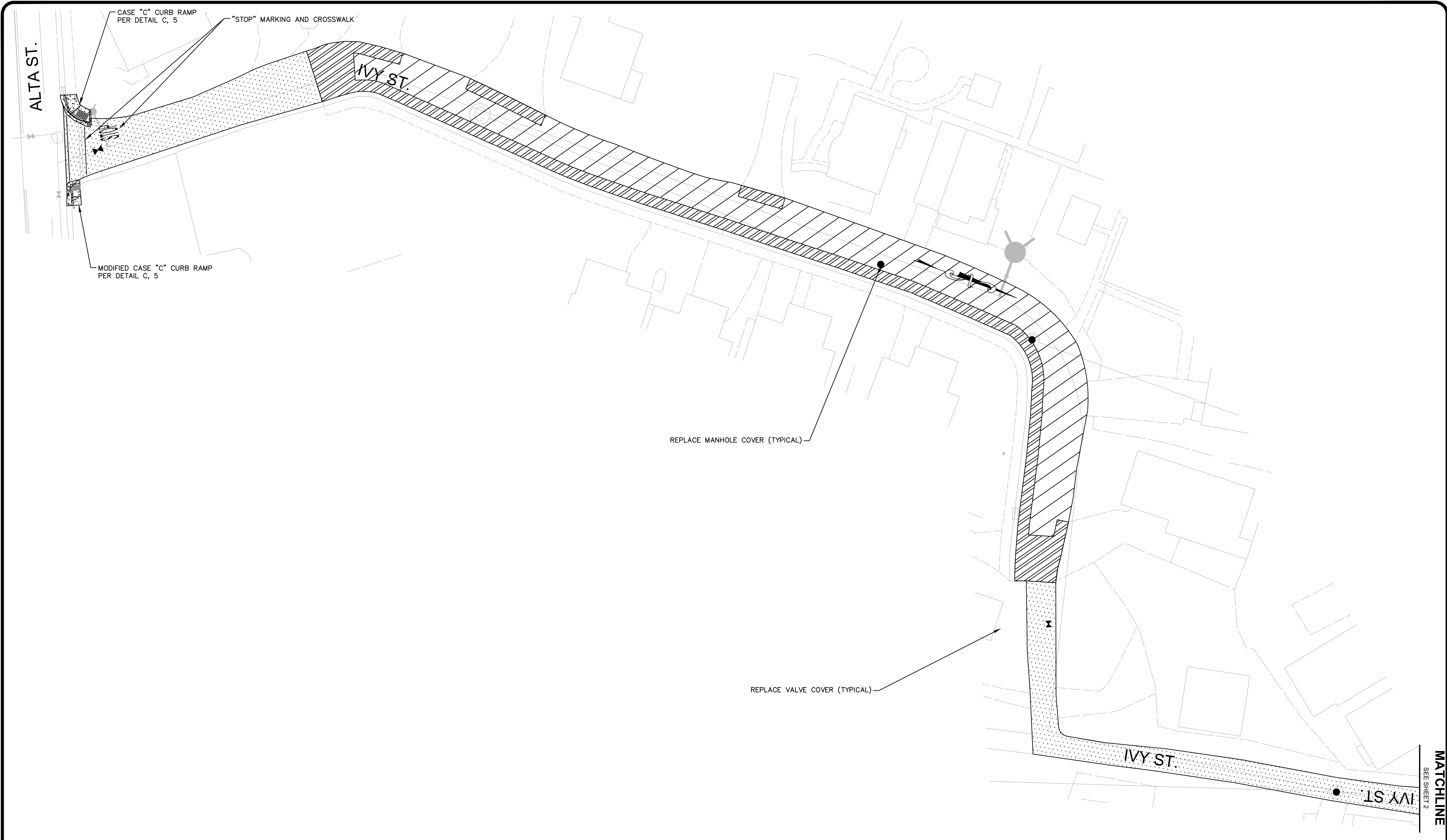

© DATA LAYER TECHNOLOGY

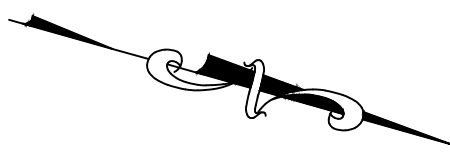

**IVY ST.**  
SCALE: 1"=20'

**GENERAL NOTES**

1. REMOVE EXISTING CONCRETE SURFACING ON NORTH CHURCH ST BETWEEN WEST MAIN ST AND RICHARDSON ST.
2. ASPHALT CONCRETE IS TO BE CONFORMED TO ALL EXISTING PAVED/CONCRETE DRIVEWAYS WHERE CURB AND GUTTER DO NOT EXIST.
3. ASPHALT CONCRETE IS TO BE CONFORMED TO ALL EXISTING DRAINAGE INLETS AND WATER METER BOXES
4. ALL VEGETATION SHALL BE REMOVED INSIDE OF PROPOSED PAVEMENT LIMITS
5. CONTRACTOR IS RESPONSIBLE FOR VERIFYING LOCATION AND DEPTH OF ALL UTILITIES PRIOR TO START OF CONSTRUCTION.
6. DIGOUT LIMITS TO BE MARKED IN THE FIELD BY THE CONTRACTOR AND APPROVED BY THE ENGINEER
7. ALL UTILITY COVERS AND MANHOLES WITHIN THE HMA PAVING AREA SHALL BE ADJUSTED TO GRADE AS SHOWN OR OTHERWISE SHALL BE CONFORMED TO AS APPROVED BY THE ENGINEER AND THE OWNER.

**STRIPING/MARKING NOTES**

1. ALL PAVEMENT MARKINGS AND STRIPES SHALL BE THERMOPLASTIC, CONFORMING TO THE REQUIREMENTS OF THE CURRENT CALTRANS SPECIFICATIONS AND STANDARD PLANS AND THE PROJECT SPECIAL PROVISIONS, UNLESS OTHERWISE SPECIFIED. ALL CENTER LINE STRIPES SHALL BE 4" IN WIDTH.
2. TEMPORARY PAVEMENT MARKINGS SHALL BE PROVIDED IN ACCORDANCE WITH THE SPECIAL PROVISIONS.
3. THE CONTRACTOR SHALL MARK OUT THE STRIPING LAYOUT AND OBTAIN THE ENGINEER'S ACCEPTANCE PRIOR TO STRIPING. CHANGES MAY OCCUR IN THE FIELD.

- REPLACE VALVE COVER AND ADJUST TO GRADE PER DETAIL A, 6
- REPLACE MANHOLE COVER AND ADJUST TO GRADE PER DETAIL A, 6
- 3" REMOVE AND REPLACE HMA PER DETAIL D, 6
- 5" REMOVE AND REPLACE HMA PER DETAIL E, 6
- 1.5" HMA OVERLAY PER DETAIL F, 6
- TAPER GRIND & 1.5" HMA OVERLAY PER DETAIL F, 6

**NOTE:**  
THE CITY OF GRASS VALLEY OR ITS OFFICERS OR AGENTS SHALL NOT BE RESPONSIBLE FOR THE ACCURACY OR COMPLETENESS OF ELECTRONIC COPIES OF THIS PLAN SHEET.

MATCHLINE  
SEE SHEET 2

REVISIONS			
No.	Description	Engr Init	By Date



PROJECT NUMBER:  
**23-09**

CITY OF GRASS VALLEY ENGINEERING DIVISION  
**2024 ANNUAL MEASURE E  
STREET REHAB PROJECT**  
IVY ST



DRAWN BY: **EMA** DATE: **JAN 2024**  
CHECKED BY: **BPJ** DATE: **JAN 2024**

DRAWING NUMBER:  
**2201**  
SHEET NUMBER:  
**5 OF 6**

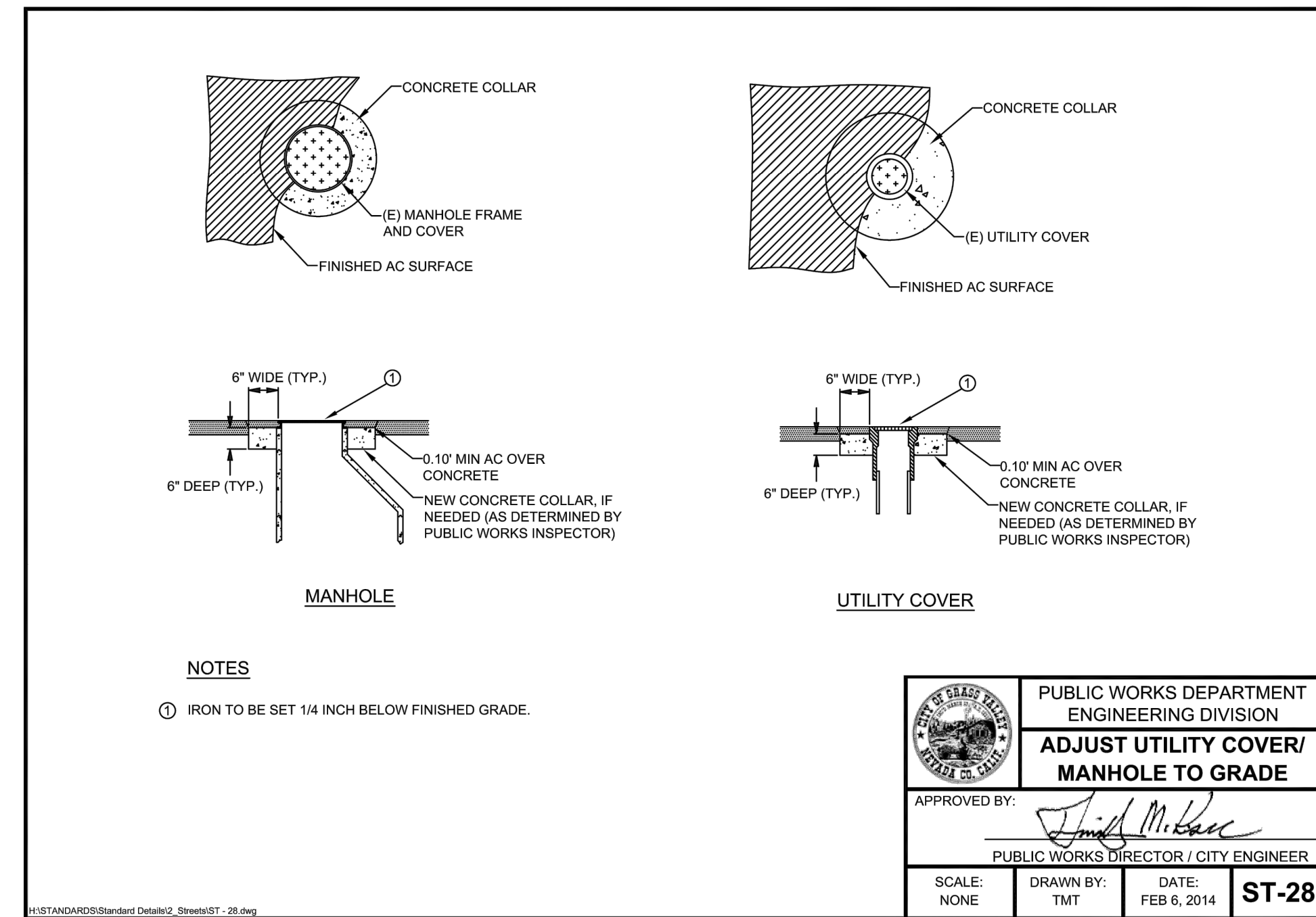

**A** ADJUST UTILITY COVER / MANHOLE TO GRADE  
**5** NOT TO SCALE

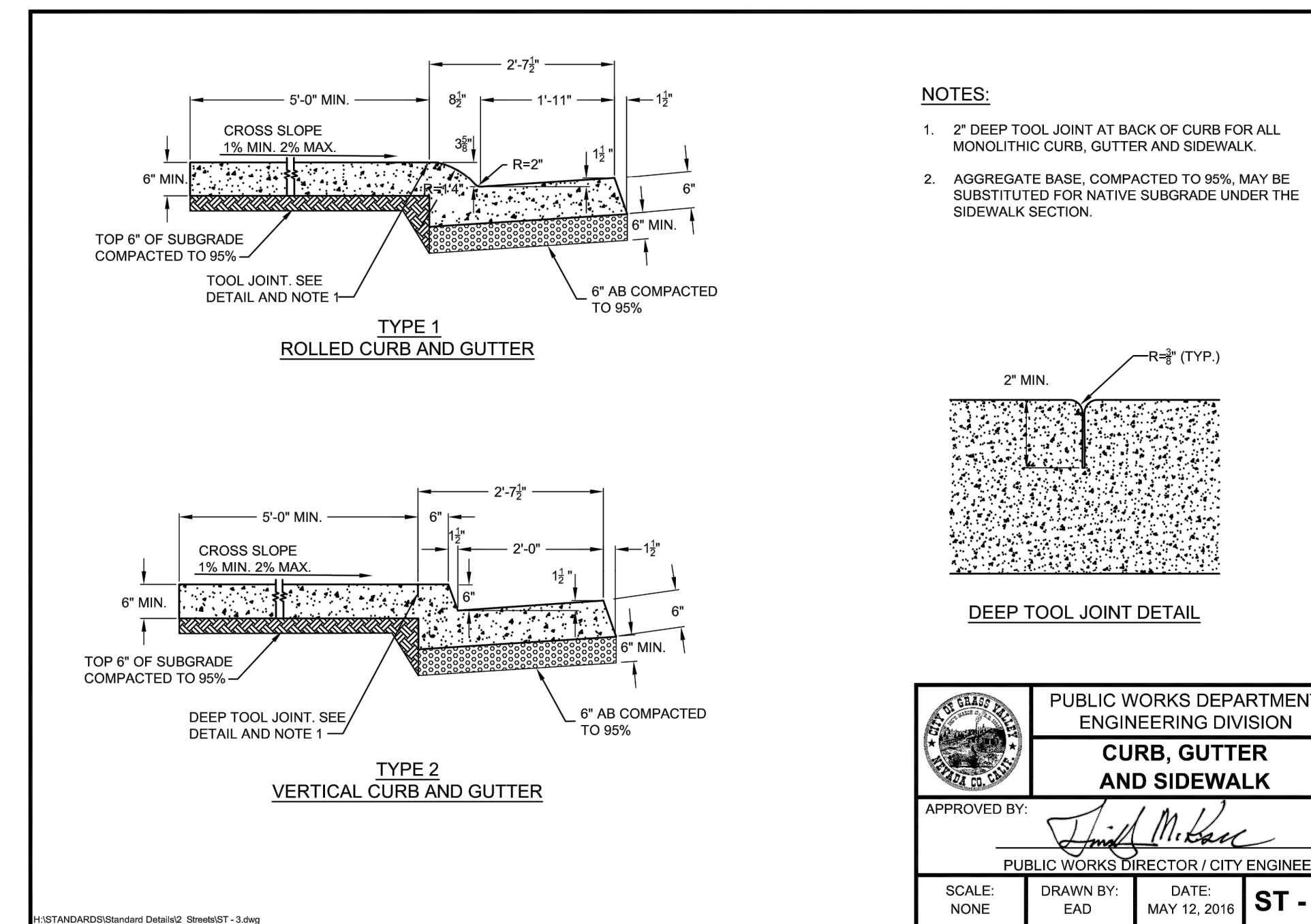

**B** CURB, GUTTER AND SIDEWALK  
**5** NOT TO SCALE

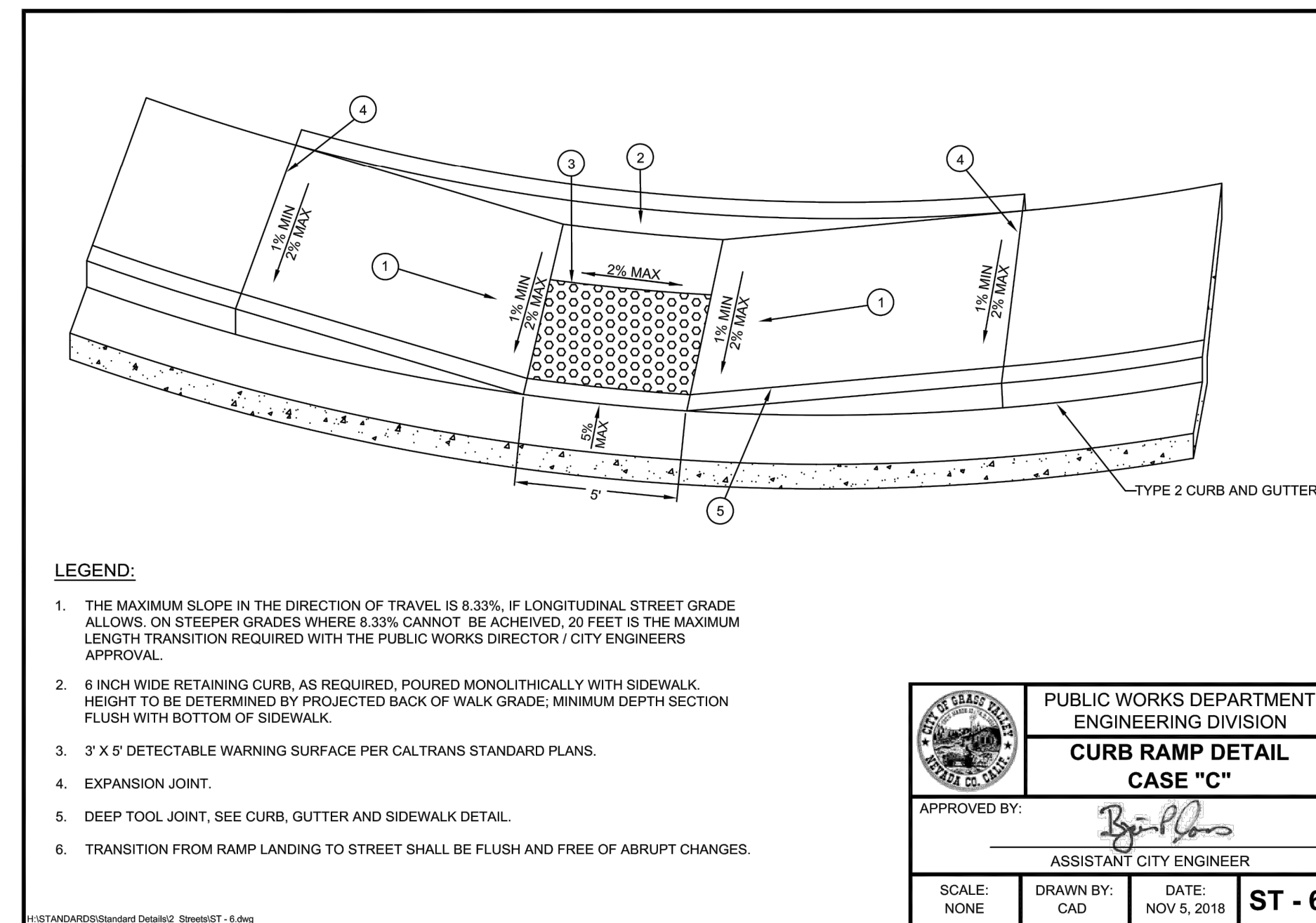

**C** CURB RAMP CASE "C"  
**5** NOT TO SCALE

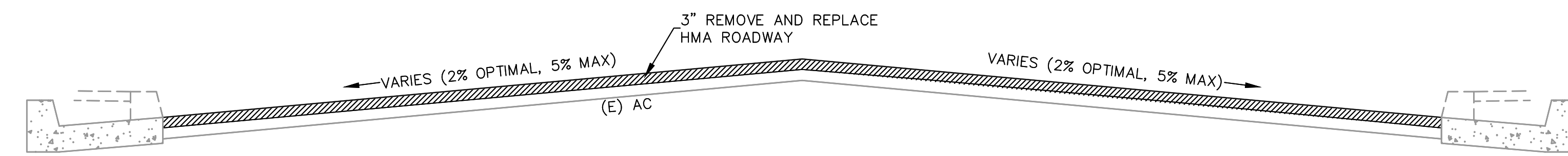

**D** STREET CROSS SECTION  
**5** 3" REMOVE AND REPLACE HMA  
 NOT TO SCALE

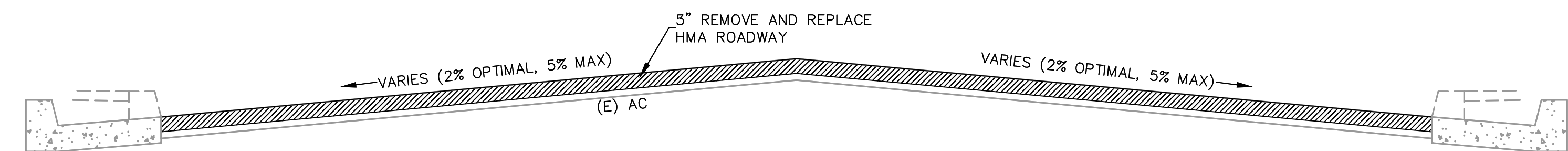

**E** STREET CROSS SECTION  
**5** 5" REMOVE AND REPLACE HMA  
 NOT TO SCALE

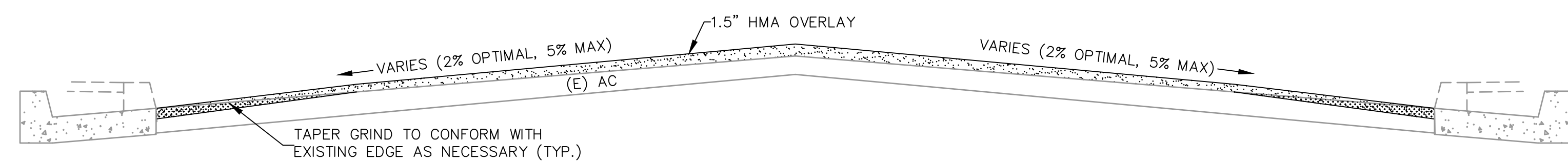

**F** STREET CROSS SECTION (ROAD OVERLAY)  
**5** 1.5" HMA OVERLAY W/ TAPER GRIND AS NECESSARY  
 NOT TO SCALE

NOTE:  
 THE CITY OF GRASS VALLEY OR ITS OFFICERS OR AGENTS SHALL NOT BE RESPONSIBLE FOR THE ACCURACY OR COMPLETENESS OF ELECTRONIC COPIES OF THIS PLAN SHEET.

REVISIONS	
No.	Description

PROJECT NUMBER:  
**23-09**

CITY OF GRASS VALLEY ENGINEERING DIVISION  
**2024 ANNUAL MEASURE E**  
**STREET REHAB PROJECT**  
 DETAILS



DRAWN BY:	DATE:
EMA	JAN 2024
CHECKED BY:	DATE:
BPJ	JAN 2024
DRAWING NUMBER:	
<b>2201</b>	
SHEET NUMBER:	
<b>6 OF 6</b>	