

SECTION 8

LANDSCAPING & IRRIGATION (LS)

- 8-1 GENERAL** - All landscaping and irrigation improvements shall be installed in accordance with the approved project improvement plans, these Construction Standards, the latest edition of Caltrans Standard Specifications, as recommended by the manufacturer and as specified by the City Engineer. These Construction Standards and the manufacturer's guidelines shall be present at the construction site at all times.
- 8-2 IRRIGATION INSTALLATION** - It is the intention of these standards to establish the specifications and work required for the installation of a sprinkler system, which will operate in an efficient manner and provide adequate coverage over the entire irrigated area. These specifications and the standard details indicate the general arrangement of piping and equipment, and do not necessarily detail all offsets, fittings and accessories that may be required. The Contractor shall furnish incidental materials and labor required to complete the work to the satisfaction of the City Engineer.
- A. Trenching** - Trench excavation shall be open vertical construction, sufficiently wide to provide free working space around the work to be installed, and to provide ample space for backfilling and compacting. Trenches for pipe shall be cut to required grade-lines, and the trench bottom shall be compacted to provide an accurate grade and uniform bearing for the full length of the line.
1. When two pipes are to be placed in the same trench, the trench shall be wide enough to allow for 6-inches of separation between the pipes and/or conduits.
 2. The excavation required for the installation of conduit, foundations and other appurtenances shall be performed in such a manner as to cause the least possible damage to the streets, sidewalks and other adjacent improvements.
 3. The minimum cover requirements above the conduit or wiring are:
 - a. 12- inches over non-pressure, lateral lines.
 - b. 18- inches over pressurized main lines.
 - c. 24- inches over pipe crossing underneath pavement.
- B. Backfill** - Backfill material in non-paved areas shall be native material free from lumps or stones and placed in six (6) inch layers thoroughly compacted by mechanical tamping.
- C. Control Wiring** - Connections between the automatic controllers and the electric control valves shall be made with direct burial copper wire AWG-U.F. 600 volt.
1. Two spare wires of different colors shall be run from the valve furthest from the controller, back to the controller. Pilot wires shall be of a different color for each automatic controller.
 2. Common wires shall be white with different color stripes for each automatic controller. Installations to be made in accordance with the valve manufacturer's recommendations and wire chart. Wire size shall be no less than #14.
 3. Wiring shall occupy the same trench as pressure supply or lateral lines. The wiring shall be the same elevation as the supply or lateral lines.

4. When more than one wire is placed in a trench, the wiring shall be taped together at intervals of four (4) feet to six (6) feet.
5. Wires installed in conduits shall not be taped together to facilitate replacement of individual wires.
6. An expansion curl should be provided within three (3) feet of each wire connection and at least every 100-feet of wire length. Expansion curls shall be formed by wrapping at least five (5) turns of wire around a one-inch diameter pipe, then withdrawing the pipe.
7. Field splices between the automatic controller and electric control valves will not be allowed without the approval of the City Engineer.

D. Irrigation Controller - The controller shall be a solid-state unit capable of fully automatic or manual operation of the system. Placement of the controllers will be coordinated with the Public Works Inspector. All local and applicable codes shall apply in installing the 120-volt electrical service to the controller. The Contractor shall provide the electrical service connections from the power service point to the controller. Adequate coverage and protection of the 24-volt service wire leading from the controller shall be maintained from the bottom of the controller.

E. Conduits - Interconnect conduit and fittings shall be PVC schedule 40.

1. Conduit runs shall be installed as shown in the approved plans. Any changes shall be approved by the City Engineer prior to installation.
2. The ends of the conduits, whether shop or field cut, shall be reamed to remove burrs and rough edges. Cuts shall be made square and true.
3. Conduit bends, except factory bends, shall have radii of not less than six times the inside diameter of the conduit.
4. Conduit shall be installed at a depth of not less than 18-inches below finished grade.
5. Conduit shall be free of soil and debris.
6. A nylon or polypropylene pull rope with a minimum tensile strength of 500 pounds shall be installed in all conduits, which are to receive future, interconnect cable. At least 2 feet of pull rope shall be extended beyond each end of the conduit run and secured.
7. Conduit placed under pavement shall be installed in a schedule 40 PVC sleeve sized as required.

F. PVC/Brass Pipe - All irrigation pressure lines shall be appropriately sized PVC or brass pipe.

1. PVC pipe shall be cut with a fine-toothed hacksaw or approved cutting tool and any burrs shall be removed. The outside of the pipe and the inside surface of the fittings shall be wiped with a clean cloth and then primed to remove all dirt and moisture prior to applying cement solutions.
2. Joining of PVC pipe shall be accomplished by brushing the cement solution uniformly around the pipe and fitting socket. Immediately after the cement application, the pipe shall be inserted into the fitting with a twisting motion to the full depth of the fitting socket. Any excess cement shall

be thoroughly wiped from the pipe and fitting. The joined members shall be allowed to cure for at least 5-minutes before they are handled. An additional fitting or pipe section may be added to the completed joint within 3-minutes if care is exercised in handling so that a strain is not placed on the previous joint.

3. Except as shown on the approved plans, PVC pipe shall be laid in a level trench on compacted or undisturbed earth and solvent-weld pipe shall be placed from side to side in the trench at intervals of approximately fifty (50) feet.
4. Brass pipe joints shall be threaded couplings, rated at 150-psi. Threaded joints shall be made by placing Teflon tape on the male threads only. Use of thread cement or caulking to make the joints tight is not permitted. All cut ends shall be reamed to full pipe bore before assembly. Brass pipe fittings shall be joined to the pipe in the same manner as specified for pipe joints.
5. All main lines shall have a bare copper trace wire installed, running the entire length of the main.
6. All taps on main lines three (3) inches or larger shall be made with saddle taps.
7. All piping under pavement shall be installed in a schedule 40 PVC sleeve twice the diameter of the water line.

G. Sprinkler Heads - Sprinkler heads shall be set perpendicular to finished grade and shall be installed as indicated on the approved plans and as shown in the Standard Details. Nozzles on stationary sprinklers shall be securely tightened after installation, and sprinklers having an adjustment stem shall be adjusted for proper radius and throw.

H. Valves - All valves shall be installed as indicated on the approved plans and as shown in the Standard Details. Each valve assembly shall have its own outlet; multiple assemblies are not allowed.

I. Valve Boxes - All gate valves, manual angle or globe valves shall be installed in a plastic valve box as shown in the Standard Details, complete with cover, unless otherwise specified on the approved plans.

1. All valve boxes shall be set ¼-inch above finish grade in lawn areas and two (2) inches above finish grade in ground cover areas. Valve boxes in athletic field areas shall be set twelve (12) inches below grade.
2. Valve boxes located near walks, curbs, header boards or paving shall be installed in such a way as to allow for valve boxes to abut those items with top surface matching planes.
3. All valve boxes shall be blocked for support with brick or concrete block.

8-3 IRRIGATION TESTING - All irrigation lines shall be pressure tested prior to trench backfill.

A. Service Lines and Irrigation Main - Upon completion of the main line distribution system, lateral lines and installation of the electric control valves, the system shall be flushed and then capped. After notifying the Public Works Inspector 72-hours in advance, the system will be pressure tested by applying a continuous static water pressure and shall meet the these conditions:

1. Main lines to hold 150-psi for four (4) hours.

2. Lateral lines to hold line pressure for four (4) hours.
- B. Leak Repair** - Repair any leaks resulting from the pressure tests. Pressure testing shall continue until no leakage or loss of pressure is shown over the entire prescribed test period. At the conclusion of the pressure tests, the heads shall be installed and tested for operation in accordance with design requirements under normal operating pressures.
- C. Electrical System** - Prior to the acceptance of the improvements, the Contractor shall pass the following tests to the electrical system:
1. Continuity of each circuit.
 2. Grounds in each circuit.
 3. A functional test in which it is demonstrated that each and every part of the system functions as specified or intended herein.

8-4 PLANTING INSTALLATION -

- A. Soil Preparation** - Prior to any planting, finish grade all planting areas, filling as needed or removing surplus dirt. Float areas to a smooth, uniform grade and slope to drain as indicated on the approved plans. Roll, scarify, rake and level as necessary to obtain true, even planting surfaces and thoroughly wet down the soil. After allowing to dry the planting area shall be cultivated to a depth of twelve (12) inches and allowed to dry out.
- B. Soil Conditioning** - Soil amendment and fertilizers shall be spread evenly over all areas. Fertilizer and soil amendment shall be applied per the soils fertility analysis and incorporated into the top twelve (12) inches of soil by repeated rotary-hoe cultivation.
- C. Fine Grading** - All planting areas shall be finish graded to a smooth even plane with no abrupt change of surface. Tops and toes of slopes shall be rounded to produce gradual transitions.
1. Planting areas, including lawns, shall be true to grade within one (1) inch tested in any direction with a ten (10) foot straightedge.
 2. Finished grades of all shrubs, annuals and ground cover areas shall be one (1) inch below top of adjacent structural elements unless otherwise indicated on the approved plans.
 3. Finished grades of lawn areas shall be ½-inch below top of adjacent structural elements.
- D. Tree, Shrub, and Ground Cover Planting** - Trees, shrubs, and ground cover shall be planted per the approved plans and the following:
1. **Locations** - Tree and shrub locations shall be approved by the Public Works Inspector prior to plant holes being dug.
 2. **Pit Digging** - Dig circular pits, 3 times the diameter of the planting can.
 3. **Root Balls** - Plants are to be lifted so that the root ball is supported from the underside. Plants that do not have a satisfactory root system will be rejected. If plants do not have young feeder roots showing at the edge of the container, loosen their roots and cut in several places to

encourage new feeder root development along the perimeter of the root ball. Root balls are to be checked for girdling roots around the stems.

4. **Planting plants** - All plants shall be planted immediately after the containers are cut and containers shall be immediately removed from the site. Ground cover shall be installed at spacing indicated on the approved plans and shall be evenly spaced and staggered in rows. Place each plant in a pit so the root system lies free without doubling and so the roots are planted vertically. Firm the soil around each plant and water the area immediately to avoid drying out.
5. **Planting trees** - All trees shall be planted in an upright position on a packed mound, with the crown of the tree two (2) inches above grade at the time of planting. Place approved fertilizer tablets and backfill until the hole is one half (½) full, thoroughly water, then complete backfilling. Place a three (3) inch high berm outside the excavated area, and fill the watering basin with water. Basins are not required if plants are in a lawn area or are watered by an emitter system. Mulch is not to be placed within the basin areas, or within six (6) inches of the stems for areas without basins.
6. **Fertilizers** - Apply fertilizer consisting of a mixture of 16% nitrogen, 6% phosphorous, 8% potassium (16-6-8) at a rate of five (5) pounds per 1,000 square feet, uniformly over area to receive ground cover.
7. **Supporting trees** - After pruning off any suckers as needed, place stakes along the side of the root ball and two (2) feet into undisturbed soil. Trees are to be tied to the stakes per the Standard Details. No mulch is to be placed within the tree basin, or within six (6) inches of the stem, if a basin is not required.

E. Hydromulch Seeding -

1. **Preparation** - The slurry preparation shall take place on site. When the water level in the tank has reached the height of the agitator shaft and good circulation has been established the seed shall be added. Fertilizer shall then be added, followed by wood pulp. The wood pulp shall be added to the mixture after the seed and only when the tank is at least one-third filled with water. All the wood pulp shall be added by the time the tank is 2/3 to 3/4 full. Spraying shall commence immediately when the tank is full.
2. **Application** - Areas to receive hydromulch shall be sprayed with a uniform, visible coat by using green color wood pulp as a guide. The slurry shall be applied in a sweeping motion, in an arched stream, allowing the wood fibers to build on each other until a good coat is achieved. Application rates shall be based on site conditions and season. Hydromulch shall not be allowed to fall on the ground cover and shrub areas.
3. **Time Limit** - Any slurry mixture which has not been applied to the slope within four (4) hours of mixing will be rejected by the Public Works Department and shall be removed from the project at the Contractor's expense.

F. Seeding - Installation of all plants and ground cover shall be complete prior to seeding operations. Just prior to sowing, areas to be seeded shall be made sufficiently loose and friable to receive the seed.

1. **Application** - Seed shall be sowed evenly using a mechanical spreader at the rate specified on the approved plans. One-half the seed shall be sowed in one direction, and the remaining one-half

sowed in a direction 90 degrees to the first during a windless period. Turf seed shall be applied with an implant seeder that implants the seed into the soil. Broadcast seeding is not allowed for turf seed. Apply fertilizer (16-6-8) at a rate of five (5) pounds per 1,000-square feet uniformly over seeded areas. Lightly rake surface to cover seed and to mix with fertilizer and then compact with a 200 pound roller. Soil shall be kept moist but not saturated until the seed has germinated.

2. **Protection** - Protect grass areas with temporary fencing as necessary. Barriers shall be maintained by the Contractor and kept in orderly condition at all times until work has been accepted by the City. Any damage to turf shall be repaired at the expense of the Contractor.

G. Sod Planting -

1. **Application** - Unroll the sod, fitting each strip tightly to the preceding strip. Do not stretch the sod. Stagger the strips of sod to prevent the seams on adjacent rows from matching. Care shall be taken to prevent heel or foot prints in the grade as the sod is being placed.
2. **Rolling** - As soon as the sod is placed, roll it with a light roller, making certain that no air space is left under the sod. After the first rolling, moisten the sod lightly and then allow the grass to dry before the second rolling. The second rolling should be at a cross angle to the first rolling.
3. **Maintenance** - Upon completion of the rolling, apply sufficient water to wet the sod and soil to a depth of six (6) inches. Sod shall be kept moist for the next ten (10) days. The grass is to be mowed to a height of two (2) inches at the end of the ten (10) day period. Care shall be taken to leave no footprints in the sod.

8-5 MAINTENANCE PERIOD -

- A. **Preliminary Inspection** - Upon completion of all irrigation and planting work, the Contractor shall notify the City that the landscaping is ready for preliminary inspection. The approval of the completed work will establish the beginning of the maintenance period.
- B. **Maintenance Period** - The maintenance period shall be 90-calendar days from the approval of the constructed improvements. A longer period may be required at the discretion of the City Engineer.
- C. **Overall Maintenance Requirements** - During the maintenance period the Contractor shall be responsible for all watering, weeding, mowing, fertilizing, cultivation, spraying and pruning necessary to keep the plant material in a healthy, growing condition and to keep the planted areas neat and attractive in appearance. Maintenance shall also include responsibility for maintaining adequate protection for all landscaped areas.

During the maintenance period, any plants that are vandalized, diseased, dead or in an unhealthy condition shall be replaced by the Contractor at his own expense within two (2) weeks after notification from the City Engineer, at no additional cost to the City. At the end of the maintenance period, all plant material shall be in a healthy, growing condition and free of physical injury of any kind. All items and equipment shall be maintained in an optimum working condition.

- D. **Watering** - All plants shall be watered not less than twice a week. Each watering shall be of such quantity as to provide optimum growth conditions.
- E. **Lawn Maintenance** - Lawn areas which fail to germinate shall be re-seeded at maximum ten (10) day intervals until a vigorous, uniform stand of turf is established. Lawn areas shall be kept free of

weeds, by hand pulling, or they may be sprayed with an approved selective chemical herbicide before the weeds exceed two (2) inches in height.

Lawns shall be mowed for the first time after establishment of a vigorous, uniform stand of turf has reached three (3) inches. Lawns shall be trimmed at the edges of curbs, walks, paving and other surface improvements. Lawn shall be mowed a second time when it again reaches a three (3) inch height, except that the second cutting shall be performed no sooner than ten (10) days after the first. Mowing shall then take place at maximum one (1) week intervals until final acceptance. After the second mowing, apply the second application of fertilizer. Apply fertilizer (16-6-8) at the rate of five (5) pounds per 1,000-square feet uniformly over the turf area.

8-6 FINAL INSPECTION AND ACCEPTANCE -

A. Final Inspection - Acceptance of the project by the City will be contingent upon proper maintenance and the establishment of a vigorous, uniform stand of turf, healthy plants, weeded site, repair of any damaged surface improvements, repair of any damaged irrigation components and a thorough cleaning of the site. The final inspection will be conducted at the end of the maintenance period. Just prior to final inspection, Contractor shall apply fertilizer (16-6-8) to the areas as follows:

15 g.c. plants	1- cup
5 g.c. plants	½- cup
1 g.c. plants	1/4-cup
Ground cover	10-pounds per 1,000-square feet
Lawn areas	5-pounds per 1,000-square feet

B. Corrective Work -

- 1. Turf** - Any portion of turf which does not show a vigorous, uniform stand shall be replaced and all lawn areas subject to continued maintenance at the Contractor's expense for an additional thirty (30) days.
- 2. Plants** - Plants, which are missing, vandalized, dead or unhealthy, shall be replaced at the Contractor's expense with the same species and sizes as specified on the approved plans. The Contractor shall make replacements within two (2) weeks after final inspection and maintain the plants for an additional thirty (30) days.
- 3. Irrigation** - The irrigation system shall be repaired to conform to the requirements of the approved plans and associated specifications.

C. Acceptance - Once all project improvements, corrective work and maintenance have been completed as specified and to the satisfaction of the City Engineer the City will assume maintenance responsibilities following the final inspection.

8-7 GUARANTEE -

A. Plants - All trees, shrubs, ground covers and other plant materials shall be guaranteed to take root, grow and thrive for a period of one (1) year after final acceptance of the work. Any trees or other plant materials that die or significantly lose the form, appearance or size as specified on the approved plans shall be replaced at the Contractor's expense. Replacements shall be made to the same specifications and materials as required on the approved plans and shall carry this same guarantee from the time they are replaced.

- B. Irrigation** - The entire sprinkler system shall be unconditionally guaranteed by the Contractor as to material and workmanship, including settling or backfilling areas below grade, for a minimum period of one (1) year following the date of the final acceptance of the work. Any operational difficulties of the sprinkler system shall be immediately corrected by the Contractor to the satisfaction of the City Engineer at no additional cost to the City.

If, during the guarantee period, settlement occurs, the Contractor shall make any necessary adjustments to pipes, valves, sprinkler heads, or sod, including the complete restoration of all damaged plantings or other improvements, at no additional cost to the City.

8-8 IRRIGATION MATERIALS -

A. Electrical -

- 1. Control Wire** - All wiring to be used for connecting the automatic controller to the electric solenoid actuated remote control valve shall be type UF-600V, solid copper, PVC insulation, single conductor, UL approved underground feeder cable.
- 2. Splice Kits** - All pilot or "hot" splicing wire at the valves or in the field shall be made using a 3M DBR Direct Bury Splice Kit #09053, or approved equal. Field splices between the controller and valves will not be allowed without prior approval of the City Engineer.

- B. Pull Box Covers** - Pull boxes shall have reinforced concrete covers and shall be inscribed "Irrigation 24 Volt". Covers shall be provided with two (2) 3/8-inch brass hold down bolts, with brass washers and nuts. Nuts shall be recessed below the surface of the cover. Pull boxes set in traffic areas shall have steel covers designed to handle vehicle loading.

- C. Irrigation Controller** - The irrigation system controller shall be a UL approved microprocessor based, solid-state unit capable of fully automatic or manual operation of the system. It shall be housed in an exterior (16 gauge) weatherproof pedestal mounted lodging case. It shall operate on 117 volts AC, 50/60 Hz power input and be capable of operating 24-volt AC electric control valves. In addition, the controller shall be equipped with or shall be capable of the following:

- 1.** Each station shall have the capability of being individually programmed to operate from one minute to nine hours and 59 minutes, in one-minute intervals.
- 2.** It shall have a quick station function that allows for rapid programming of a block of stations with the same watering period.
- 3.** It shall have three independent programs with four automatic starts per day, per program.
- 4.** Each program shall have its own percentage function which allows the watering length of all stations in the program to be changed from 0% to 300% in 1% increments.
- 5.** Each program shall be capable of being set on either a seven day weekly repeat cycle where the active days are displayed all at once, or on a skip day basis where the user may select the number of days skipped between waterings from one to thirty.
- 6.** The controller shall allow for setting in a "rain mode" for up to seven (7) days, after which it will revert to the "automatic mode".

7. Program may be protected by use of an access code.
8. Controller shall be capable of being operated manually at any time without affecting the original program.
9. The controller shall have a rechargeable battery back up to maintain time and the user's program.
10. The controller shall have a built-in self test which allows the user to check each of the following:
 - a. LED's for lighting and shorts.
 - b. The digital display for lighting and shorts.
 - c. Each key of the keyboard for integrity and proper function.
11. The controller shall be housed in a pedestal type enclosure installed on a Class A Portland Cement Concrete foundation. Enclosure shall be a weatherproof, 16-gauge zinc coated metal locking case to which two (2) keys shall be provided. Enclosure shall be grounded with a minimum 6-foot copper clad ground rod. The enclosure and accessories shall be installed in conformance with the manufacturer's instructions and recommendations.

D. Pipes and Fittings -

1. **PVC Pipes and Fittings-** All irrigation lines shall be brass or PVC, manufactured of Type 1, Grade I or II, 2,000-psi design stress compound designated as PVC 1120 or 1220, and shall conform to ASTM designation D1784 for rigid PVC compounds. All plastic fittings shall be molded Schedule 40 fittings manufactured of the same material as the pipe and shall be suitable for either solvent weld or screwed connections. Solvent weld type couplings and fittings shall have a pressure rating equal to or greater than that of the pipe and shall be a type recommended by the pipe manufacturer.
2. **Mains -** Irrigation mains shall be 3/4-inch or larger PVC Class 315. All main lines of three (3) inches or larger shall be constructed using gasketed bell joints.
3. **Service Laterals -** Laterals shall be 1/2-inch or larger PVC Class 200.

E. PVC Pipe Cements -

1. **Primer -** For all sizes of PVC pipe and fittings, primer shall be IPS P-70 PVC, Weld On #P-70 Primer, or approved equal.
2. **Cement -** For all sizes of PVC pipe and fittings, cement shall be IPS 711, Weld On #711 Glue, or approved equal.

- F. Sprinkler Heads -** All sprinkler heads shall be constructed of plastic or stainless steel and shall be matched precipitation rate (MPR) nozzles equipped with a Seal-A-Matic (SAM) check valve, or approved equal.

All sprinkler heads of a particular type or function in the system shall be of the same manufacturer and shall be marked with the manufacturer's name and identification in such a position that they can be identified without being removed from the system. All tree bubblers shall be placed below grade in perforated pipe with crushed rock and geotex fabric.

G. Sprinkler Risers - All ½-inch riser nipples shall be threaded Schedule 80 PVC and swing joints shall be Schedule 80 PVC threaded street ells. All 1-inch riser assemblies shall consist of swing joints rated at 200-psi, 2-Schedule 80 PVC nipples and 1-Schedule 80 nipples.

H. Valves and Valve Boxes -

1. **Gate Valves** - Gate valves shall be bronze body, bronze mounted, double disc, parallel seat with non-rising stem. Gate valves shall have "O" ring seals and have hubs suitable for use with the main distribution pipe furnished for the sprinkler system.
2. **Quick Coupling Valves** - Quick coupling valves shall be two-piece, 1-inch diameter Rain Bird 44RC with a coupler key, single lug-Rain Bird 44K or approved equal.
3. **Valve Boxes** - Valve boxes shall be plastic with lock snap cover, green, with the word "Irrigation" embossed on the cover. Valve boxes shall be of the Brooks 1100 series, or approved equal. Valve boxes installed below the finish grades shall also include a 3M Marling Ball, or approved equal.

8-9 PLANTING MATERIALS -

A. Backfill - Backfill used in tree and shrub holes shall be a mixture of soil amendment (one-third) and excavated material (two-thirds), thoroughly mixed.

B. Fertilizer - Fertilizer shall be a commercial fertilizer in the granular or pellet form. Fertilizer shall be delivered to the site in containers labeled in accordance with the applicable State of California regulations, bearing the warranty of the producer for the grade furnished, and shall be uniform in composition, dry and free-flowing.

1. **Turf and Planting Areas** - Pelleted types with analysis of 16-6-8.

2. **Planting Holes** - Tablet types with an analysis of 20-10-5, Agriform Blue-Chip Tablets, 21- gram size, or approved equal.

C. Herbicide - A list of approved products include: Surflan, Ronstat G, Ronstat WP, or approved equal.

D. Hydromulch Seeding -

1. **Seed** - As specified on the approved plans.

2. **Fertilizer** - Rate shall be applicable to site and type of seed used.

3. **Cellulose** - The mulch shall be a green colored, fibrous, wood cellulose mulch containing no growth or germination inhibiting factors. It shall be manufactured in such a manner that after addition and agitation in slurry tanks with fertilizer, seed, water, and other approved additives, the fibers in the material will become uniformly suspended to form a homogeneous slurry; and, that when hydraulically sprayed on the ground, the material will form a blotter-like ground cover impregnated uniformly with seed and mulch.

After application, this mixture will allow for the absorption of moisture and allow the rainfall to percolate to the underlying soil. Cellulose shall be certified to indicate that laboratory and field-

- testing of the product has been accomplished and that it meets all of the foregoing requirements. Weight specification of this material from suppliers, and for all applications, shall refer only to air-dry weight of the fiber material. Cellulose rate shall be applicable to site and type of seed used.
4. **Water** - Water for hydromulching shall be clean, potable and added to the slurry mixture in sufficient amount to uniformly spread the required quantity of hydromulch solids (approximately 3,000 gallons per acre).
 5. **Equipment** - Hydromulching equipment used for the application of the seed, fertilizer and slurry shall have a built-in agitation system and operating capacity sufficient to agitate, suspend and homogeneously mix a slurry containing up to 40-pounds of fiber, plus a combined total of 70-pounds of fertilizer solids and seed for each 100-gallons of water. The slurry distribution lines shall be large enough to prevent stoppage. This discharge line shall be equipped with a set of hydraulic spray nozzles which will provide a continuous non-fluctuating discharge and delivery of the slurry in the prescribed quantities uniformly, without misses, waste or erosion. The slurry tank shall have a minimum capacity of 1,000-gallons and shall be mounted on a traveling unit which may be either self-propelled or drawn. The City Engineer may authorize equipment with smaller tank capacity provided that the equipment has the necessary agitation system and sufficient pump capacity to spray the slurry in a uniform coat.
- E. Imported Topsoil** - Topsoil shall be an imported fertile, friable soil of loamy character containing a normal amount of organic matter. It shall be obtained from well-drained, arable land and shall be free from refuse, roots, heavy or stiff clay and stones larger than 1-inch in size. Soil shall, by particle examination, containing the following percentages: Sand-between 45% and 52%; Silt-between 26% and 50%; Clay-between 6% and 26%. Sands shall range from 2 to 0.05 millimeters in diameter; Silt from 0.05 to 0.002 millimeters in diameter; and Clay less than 0.002 millimeters in diameter.
- F. Mulch** - Mulch shall be a fibrous, woody bark mixture. A list of approved products includes: Sun-Up Forest Products, "Walk-on-Bark", or approved equal.
- G. Plant Stock and Ground Cover** - Plants shall be the variety, quantity and size indicated on the approved plans. Quality and size shall conform to the State of California Grading Code of Nursery Stock, No. 1 grade. Nursery grown stock only, shall be used and shall be free from insect pests and diseases. All plants shall comply with Federal and State laws requiring inspection for plant diseases and infestations. Inspection certificates required by law shall accompany each shipment of plants, and certificates shall be delivered to the Public Works Department.

Plants shall be healthy, shapely and well rooted, and roots shall show no evidence of having been root bound, restricted or deformed. Root conditions of plants in containers may be inspected by the Public Works Inspector and the City Engineer reserves the right to reject the entire lot or lots of plants containing defective samples.

Plants shall have straight trunks with the leader intact, undamaged and uncut. Trees shall be well tapered in the trunk so that they will stand alone without the support of the nursery stake. Branching on the main leader shall be in alternate locations and well spaced with no severe crossing of branches. All old abrasions and cuts shall be completely calloused over. All plants shall be measured when their branches are in their normal positions. Height and spread dimensions indicated refer to the main body of the plant, and not from branch or root, tip to tip. Plants shall be pruned prior to delivery except upon approval of the City Engineer.

Ground cover shall be rooted plants, grown in flats unless otherwise approved by the City Engineer.

Each plant shall be handled and packed in the approved manner for that species or variety and all necessary precautions shall be taken to ensure that the plants will arrive at the site of the work in the proper condition for successful growth without scarred or broken branches. Trucks used for transporting plants shall be equipped with covers to protect plants from windburn.

Substitutions will not be permitted unless proof is submitted to the City Engineer that any plant specified is not obtainable. The City Engineer will consider on a case by case basis, the use of the nearest equivalent size or variety.

- H. Seed** - Seed mixture shall be 98% pure, and noxious weed free, with a minimum of 88% Germination. Seed variety or mix shall be as specified on the approved plans. All seed shall be cleaned Grade A "new crop" seed, delivered in the original unopened containers, and shall bear a guaranteed analysis and dealer's label. The dealer may mix the seed provided a guaranteed statement or composition of mixture and percentages of purity, and germination of each variety, is attached to the sealed container. The seed shall be pre-treated with a pre-emergence fungus preventative in accordance with the manufacturer's specifications. The seed containers shall be stored immediately in a dry, weather and damp proof structure. Any seed, which has become wet, moldy or is otherwise damaged in transit or storage, will not be acceptable.
- I. Soil Amendment** - Soil amendment shall be delivered to the job site bearing the warranty of the producer for the grade furnished and shall be uniform in composition and free flowing. Grade shall be 0 to 1/4-inch with 15% maximum proportion of 1/4-inch particles. Soil amendment shall be nitrogen stabilized (1-0-0) and shall be Sequia Forest Products' Forest Humus, Mallard Creek Nitro Plus, or approved equal.
- J. Tree Stakes** - Tree stakes shall be straight, close grained hardwood, and pointed at one end. Stakes shall be pointed prior to treatment with copper naphthalene, which shall penetrate stake surfaces to a minimum depth of 1/4-inch. Tree stakes will consist of 2-inch diameter by 8-foot long, round stakes.

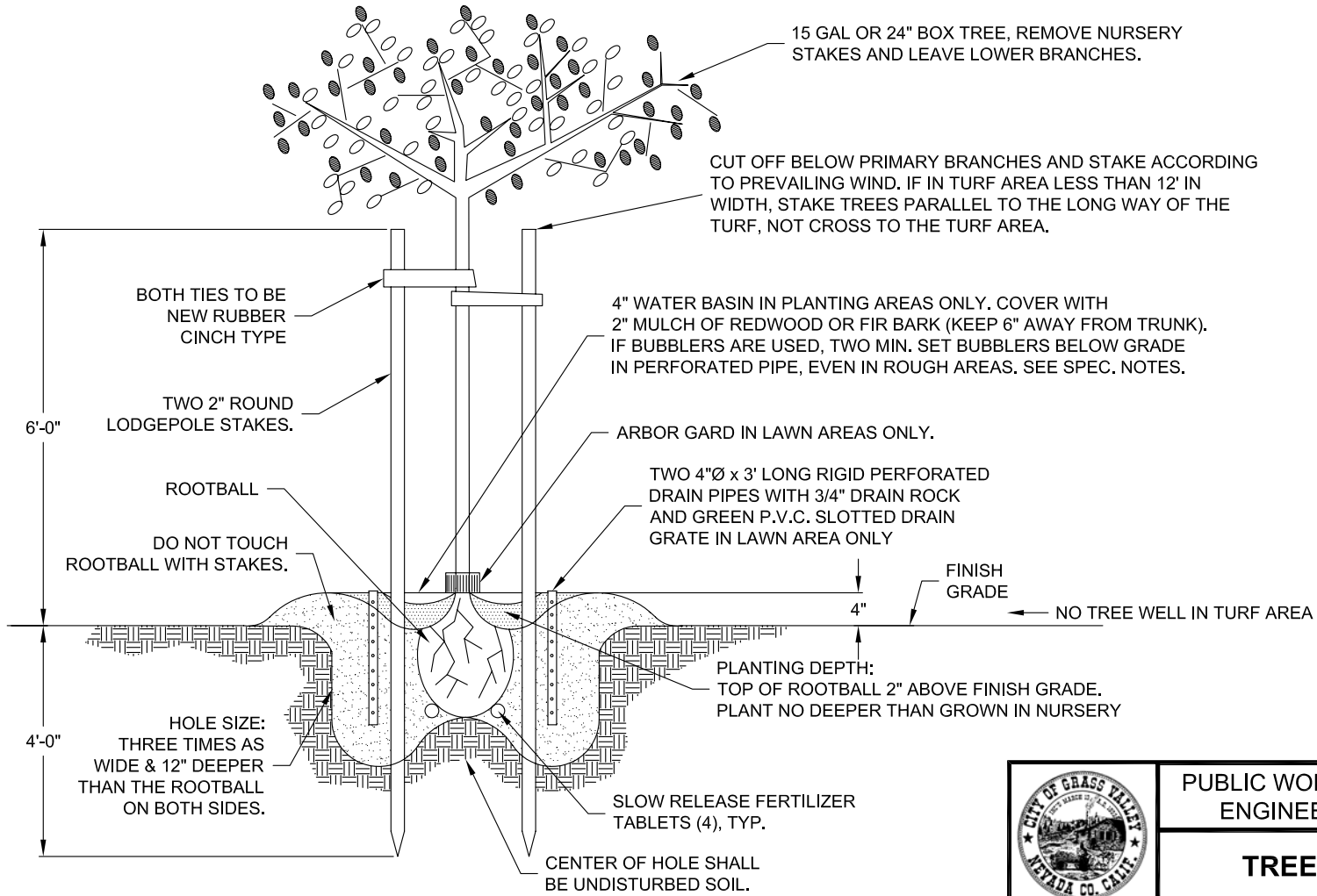



PUBLIC WORKS DEPARTMENT
ENGINEERING DIVISION

TREE PLANTING

APPROVED BY: *Jim McRae*
PUBLIC WORKS DIRECTOR / CITY ENGINEER

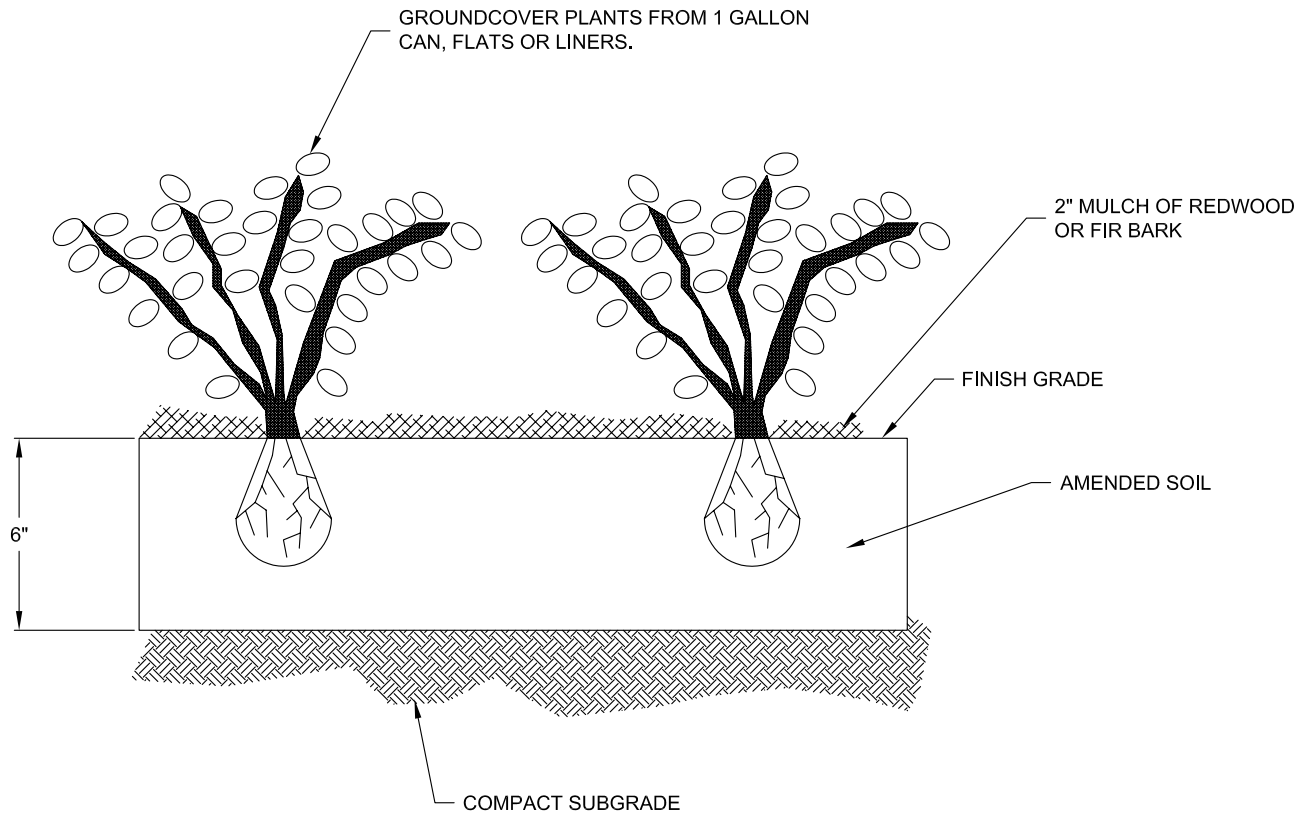
SCALE: NONE	DRAWN BY: BPJ	DATE: MAR 3, 2009	LSC-1
----------------	------------------	----------------------	--------------



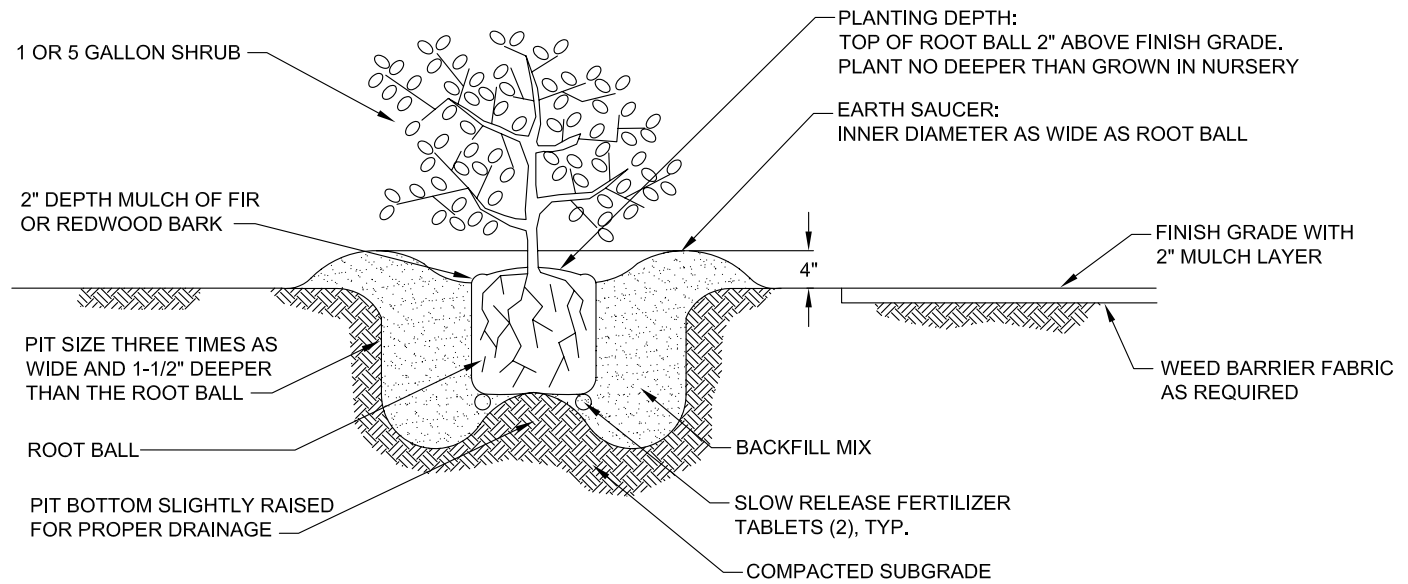

	PUBLIC WORKS DEPARTMENT ENGINEERING DIVISION	
	GROUND COVER PLANTING	
APPROVED BY: 		
PUBLIC WORKS DIRECTOR / CITY ENGINEER		
SCALE: NONE	DRAWN BY: BPJ	DATE: MAR 3, 2009
		LSC-2



NOTES:

1. PLANTER AREA SHOULD HAVE PRE-EMERGENT HERBICIDE APPLIED BEFORE PLANTING TO PREVENT GERMINATION OF WEED SEEDS.
2. WEED BARRIER FABRIC SHALL BE UTILIZED IN ALL PUBLIC MAINTAINED LANDSCAPE AREAS.

	PUBLIC WORKS DEPARTMENT ENGINEERING DIVISION
	SHRUB PLANTING DETAIL
APPROVED BY: 	
PUBLIC WORKS DIRECTOR / CITY ENGINEER	
SCALE: NONE	DRAWN BY: BPJ
DATE: MAR 3, 2009	LSC-3

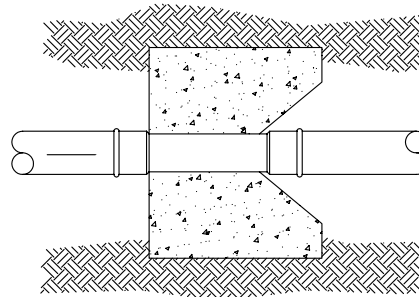
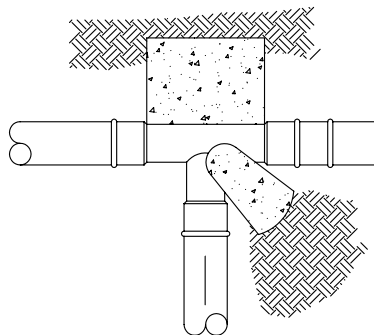
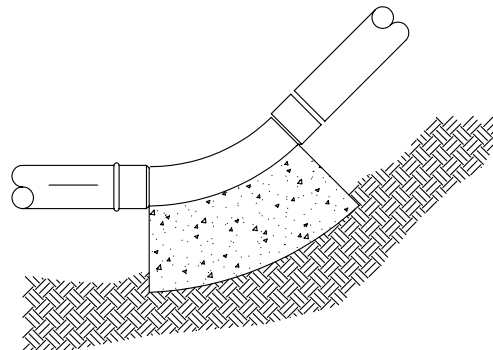
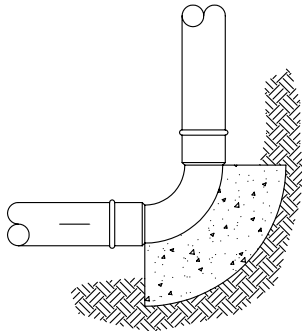
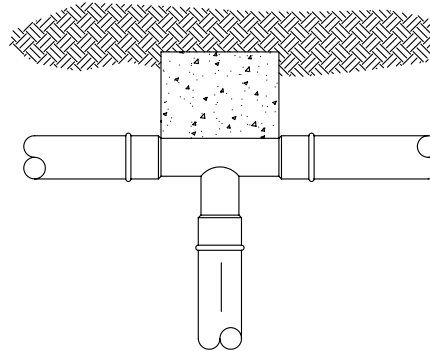
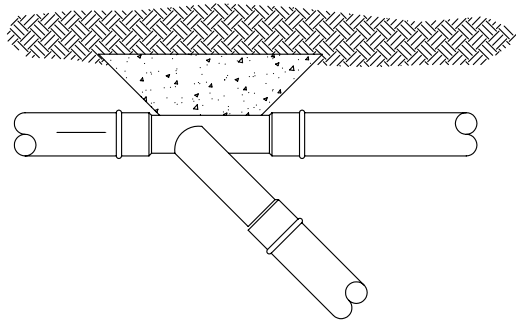

NOTES:

1. DO NOT COVER JOINTS WITH CONCRETE.
2. SIZE THE THRUST BLOCKS AS SPECIFIED BY THE PIPE MANUFACTURER.

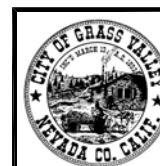

PUBLIC WORKS DEPARTMENT
ENGINEERING DIVISION

**IRRIGATION THRUST
BLOCK DETAIL**

APPROVED BY:

Jim McRae

PUBLIC WORKS DIRECTOR / CITY ENGINEER

SCALE:
NONE

DRAWN BY:
BPJ

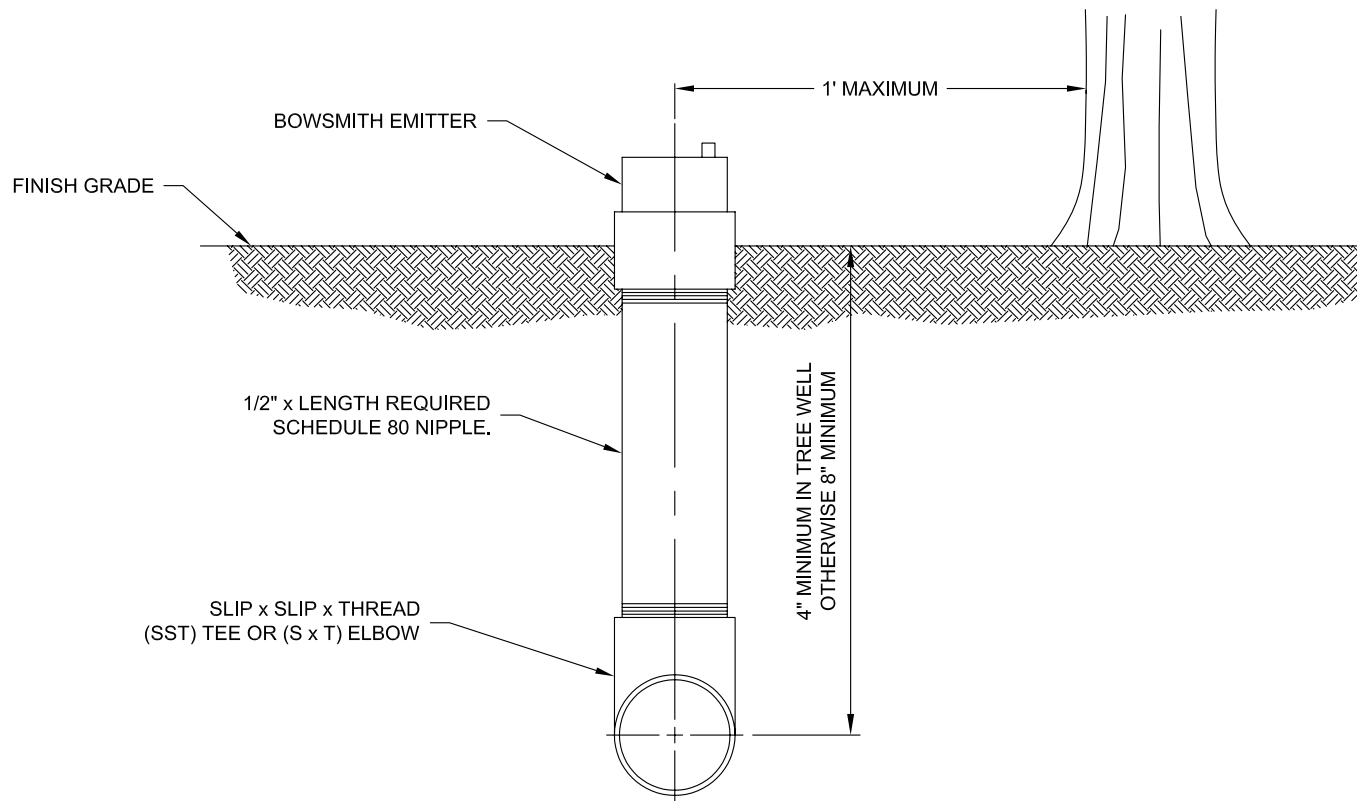

DATE:
MAR 3, 2009

LSC-4



NOTES:

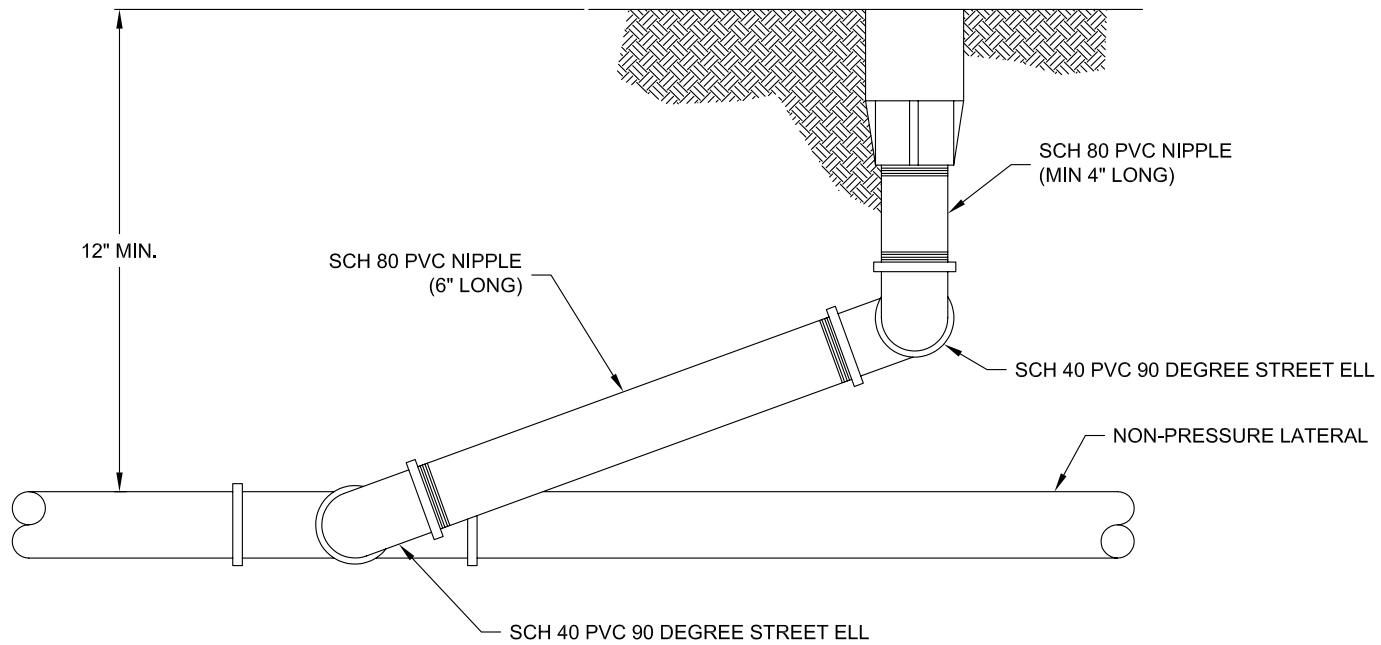

1. LOCATE EMITTER ON UP-HILL SIDE OF THE TREE OR SHRUB.
2. DO NOT TEE STRAIGHT UP OFF LATERAL. TEE HORIZONTAL THEN 90 DEGREES VERTICAL.

	PUBLIC WORKS DEPARTMENT ENGINEERING DIVISION
	ABOVE GRADE EMITTER
APPROVED BY: 	
PUBLIC WORKS DIRECTOR / CITY ENGINEER	
SCALE: NONE	DRAWN BY: BPJ
DATE: MAR 3, 2009	
LSC-5	



NOTES:

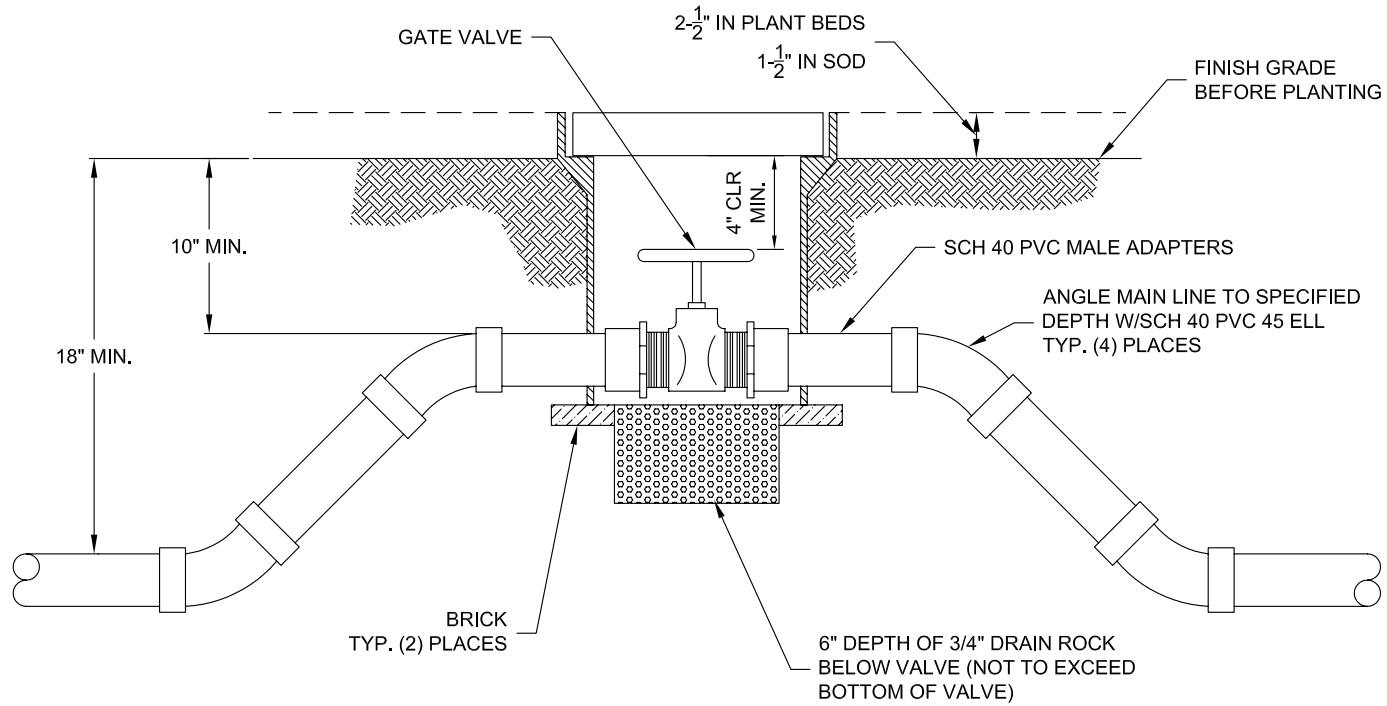

1. LOCATE HEAD 2" FROM WALKS, CURBS, HARDSCAPING, MOW STRIPS, AND HEADER BOARDS.
2. LOCATE STREAM SPRAY/BUBBLERS 6" FROM ALL STRUCTURES, AND SPRAY HEADS 12" FROM ALL STRUCTURES, BUT 6" FROM ALL STRUCTURES IN GROUND COVER AREAS.
3. USE TEFLON TAPE ON ALL THREADED FITTINGS EXCEPT BETWEEN MARLEX FITTINGS.

	PUBLIC WORKS DEPARTMENT ENGINEERING DIVISION
	POP UP SPRAY HEAD
APPROVED BY: 	
PUBLIC WORKS DIRECTOR / CITY ENGINEER	
SCALE: NONE	DRAWN BY: BPJ
DATE: MAR 3, 2009	
LSC-6	



NOTES:

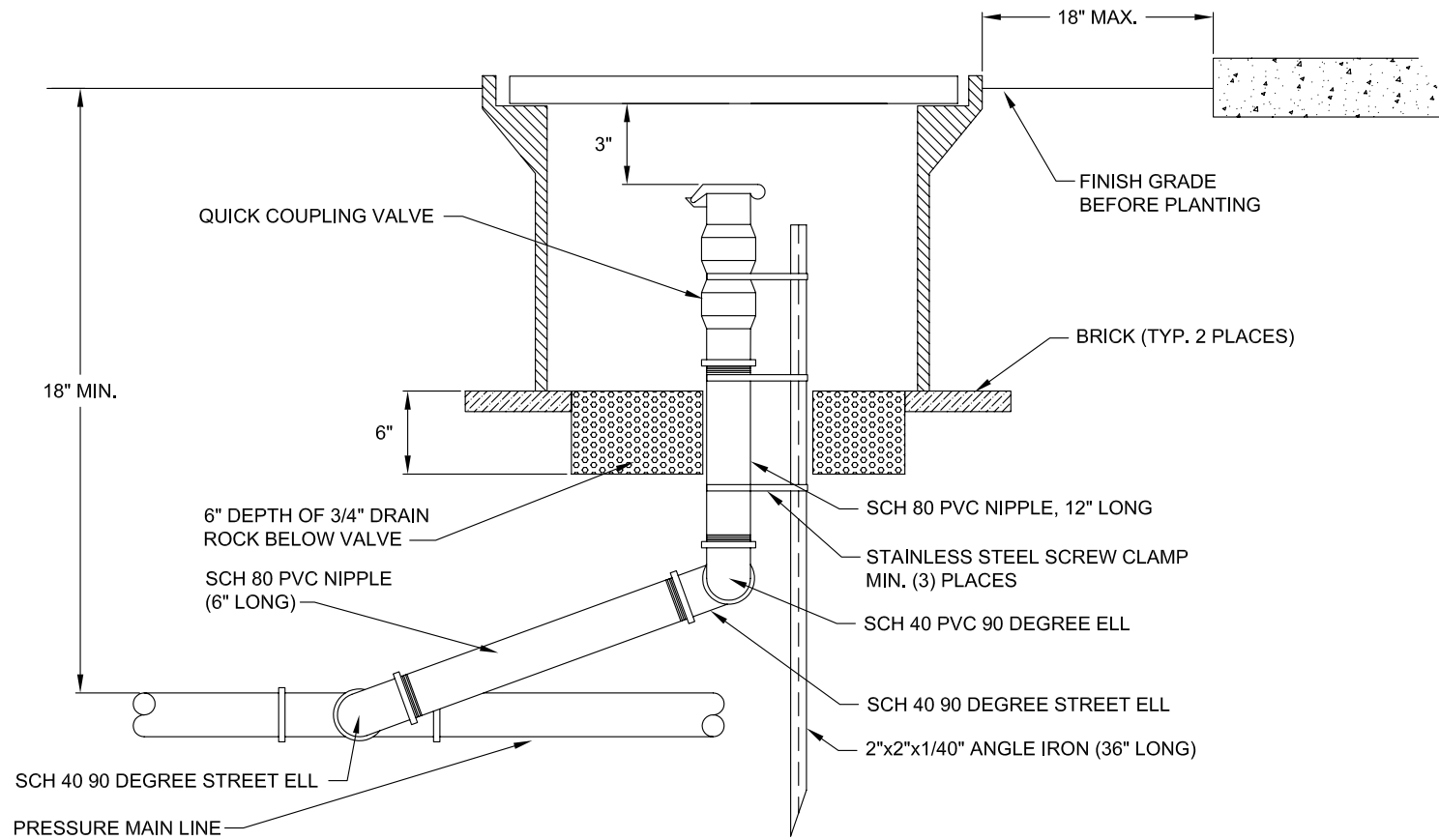

1. PLACE 3/4" DIA. ROCK PRIOR TO INSTALLATION OF VALVE BOX.
2. GATE VALVE AND FITTINGS SHALL BE LINE SIZE UNLESS NOTED OTHERWISE.
3. USE TEFLON TAPE ON ALL THREADED FITTINGS.

	PUBLIC WORKS DEPARTMENT ENGINEERING DIVISION
	GATE VALVE (3" AND SMALLER)
APPROVED BY:  PUBLIC WORKS DIRECTOR / CITY ENGINEER	
SCALE: NONE	DRAWN BY: BPJ
DATE: MAR 3, 2009	LSC-7



NOTES:

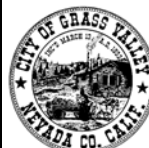

1. USE TEFLON TAPE ON ALL THREADED CONNECTIONS.

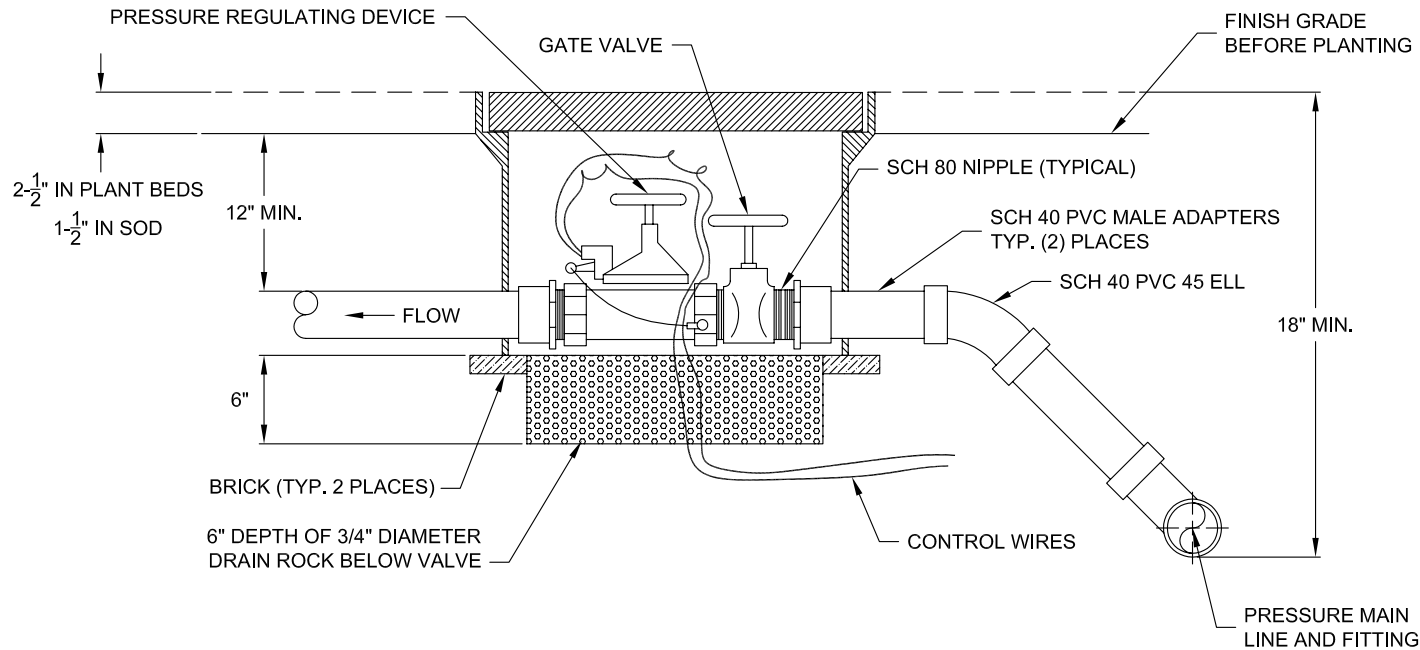
	PUBLIC WORKS DEPARTMENT ENGINEERING DIVISION	
	QUICK COUPLING VALVE	
APPROVED BY:		
 PUBLIC WORKS DIRECTOR / CITY ENGINEER		
SCALE: NONE	DRAWN BY: BPJ	DATE: MAR 3, 2009
		LSC-8



NOTES:

1. INSTALL CONTROL VALVES A MINIMUM OF 12" FROM STRUCTURES OR HARDSCAPING.
2. INSTALL VALVES IN PLANT BEDS WHEREVER POSSIBLE.
3. PLACE VALVE BOX AT RIGHT ANGLES TO STRUCTURES OR HARDSCAPING.
4. USE TEFLON TAPE ON ALL MALE THREADS.

	PUBLIC WORKS DEPARTMENT ENGINEERING DIVISION
	ELECTRIC CONTROL AND GATE VALVE
APPROVED BY: 	
PUBLIC WORKS DIRECTOR / CITY ENGINEER	
SCALE: NONE	DRAWN BY: BPJ
DATE: MAR 3, 2009	LSC-9